



HELUKABEL®



 Cables, Wires & Accessories

Aluminium Cables & Wires

Processing and Connection Technology

NOTES

Technical modifications

© HELUKABEL® GmbH Hemmingen

Specifications have been carefully checked and are believed to be correct; however, no responsibility is assumed for inaccuracies. Subject to technical modifications. Consequently all illustrations, numerical data, etc. are provided without guarantee. Color deviations between photos and delivered goods cannot be avoided. Reproduction or duplication of the text and illustrations, in whole or in part, remain reserved. The transfer of copyrights always requires the written consent of HELUKABEL® GmbH. Our General Terms of Delivery and Payment, which can be viewed at www.helukabel-group.com, apply.

Length markings

The length marking, which cannot be calibrated, is an aid, e.g. for easy material allowance determination or for determination of the length remaining on the drum. Deviation of the line length shown by the marking is up to 1%. Incomplete length markings or length markings missing on sections, deviations of the cable length shown by the length marking do not substantiate any legal obligation whatsoever. Only use calibrated measurement devices to determine line length.

Safety notice

The cables and wires described in the catalog are produced in accordance with national and international standards, as well as plant standards; application safety, as stipulated in the safety directives, standards, and statutory regulations, as amended, is provided. With the prerequisite of proper and professional installation and use, the possibility of product-specific dangers can be excluded. For each product this catalog describes general information for use. Independent of the above, the applicable DIN VDE specifications apply. However, installation and processing must only be executed by qualified electricians.

VDE approval

„Extracts from DIN standards with VDE classification are reproduced for the registered limited press run via permit no. 42.015 issued by Deutsches Institut für Normung e.V. [German Institute for Standardization] and VDE Verband der Elektrotechnik Elektronik Informationstechnik e.V. [Institute of Electrical and Electronics Engineers]. Any further reproduction or printing of these materials is subject to a specific permit. The versions of the standards with the most recent issue data are binding for the application thereof. These versions can be obtained from VDE VERLAG GMBH, Bismarckstr. 33, 10625 Berlin, www.vde-verlag.de and Beuth Verlag GmbH, 10772 Berlin.“

Our General Terms of Delivery and Payment, which can be viewed at www.helukabel-group.com, apply

We are excited to present you with the first issue of our aluminium catalogue. Aluminium cables have a long standing tradition at our company, so it only made sense to put them into a standalone publication. Aluminium conductors have traditionally been used in ground and medium-voltage applications, and only recently gained a foothold in industries such as automotive and aeroplane manufacturing. Even rigid conductors are no longer the only option. Thanks to our HELUWIND® WK POWERLINE ALU we have luckily been able to offer a highly flexible cable for several years. We developed this product in collaboration with our clients in the wind power industry. Today, other industries are benefiting from the knowledge obtained during this process. Since we are also aware that even the best wire is not worth much without the appropriate processing and electrical contacting components, we have developed a special C8-crimp technology for our fine-wire aluminium series. This process achieves the best electrical values and fulfils the high standards of IEC Norm 61238-1 Cl. A for high-current connectors.

With this in mind, we hope that this catalogue contains information that interests you and we look forward to hearing from you.



Helmut Luksch,
CEO HELUKABEL® GmbH



■ TABLE OF CONTENTS

The Benefits of Using Aluminium as a Conductor Material.....	4
Fields of Application for Aluminium Cables.....	6
ALUMINIUM CABLE RE/SE/SM 0,6/1KV	8
NAYY.....	9
NAY2Y	11
NA2XY.....	12
HELUWIND® WK (N)A2XH.....	13
NAYCWY	14
ALUMINIUM CABLE RM 6-30KV	16
NA2XSY	17
NA2XS2Y	19
NA2XS(F)2Y	21
NA2XS(FL)2Y.....	23
HELUWIND® WK POWERLINE ALU: ALUMINIUM CABLES WITH FLEXIBLE, FINE WIRE CONSTRUCTION	26
HELUWIND® WK POWERLINE ALU, 105°C 0,6/1 kV.....	27
HELUWIND® WK POWERLINE ALU robust, 105°C 0,6/1 kV	28
HELUWIND® WK POWERLINE ALU, 105°C 1,8/3 kV.....	29
HELUWIND® WK POWERLINE ALU robust, 105°C 1,8/3 kV	30
HELUWIND® WK POWERLINE ALU halogen free, 105°C 1,8/3kV	31
HELUWIND® WK POWERLINE ALU MS SINGLE, 90°C 3,6/6kV, 12/20kV, 18/30kV	32
HELUWIND® WK POWERLINE ALU MULTICORE, 90°C 0,6/1kV	33
HELUWIND® WK POWERLINE ALU SINGLE, 105°C 0,6/1kV	34
ALUMINIUM CABLE RM UL/CSA APPROVED	36
HELUWIND® WK RHH/RHW-2 ALU, UL listed RHW/RHW-2. RW90/R90, FT4 per CSA.....	37
ALUMINIUM UL listed MV-90 und MV-105, 90-105°C 2,4kV-35kV	38
SPECIAL ALUMINIUM CABLES	44
HELUWIND® WK ALU Tower, 90°C 0,6/1kV.....	45
CONNECTION TECHNOLOGY	46
Aluminium as a conductor material	47
HELU-S-PK-AL-DIN	49
HELU-S-PK-AL-FG	50
HELU-S-PK-AL/CU	51
HELU-S-PV-AL-DIN	53
HELU-S-PV-AL/CU	54
HELU-S-PAB-AL-DIN.....	55
HELU-S-PAB-AL/CU-DIN	56
WK-SC-P Bolt Connector	57
WK-SC-T Shear Bolt Connector	58
WK-SL-T Shear Bolt Cable Lug	59
Bolt Cable Lug with Shear Head.....	60

■ TABLE OF CONTENTS

CONTINUATION CONNECTION TECHNOLOGY

Bolt Connector with Shear Head.....	61
Mechanical Split Connector with Shear Head.....	62
Rollover Insulation Hose.....	63
Repair Sleeves for shielded single-conductor plastic cable.....	64
Cable Fittings.....	65
Medium-Voltage Cable Accessories.....	66
IREV-S Medium-voltage indoor termination for shrinking.....	67
FLEV-S Outdoor termination, shrinking type.....	68
Cable Fittings.....	69
SK-D, Heat-shrink tube 3:1 with inside adhesive, polyolefine, thick-walled.....	70
Connection technology for HELUWIND® WK POWERLINE ALU Series.....	71

TOOLS 72

WK-API 18.....	73
WK-electro-hydraulic, battery-operated pump.....	74
WK-electro-hydraulic radial-piston-pump (230 V) with transport cart.....	75
HELUTOOL HMPI 20 Mechanical hand press in toolbox.....	76
HELUTOOL HHPI 20 Hydraulic hand press in toolbox.....	77
HELUTOOL HAPI 20 Electro hydraulic tool in toolbox.....	78
HELU-S-PE-SK Inserts hexagonal shape.....	79
Cable Shear KST 1.....	80

CURRENT-CARRYING CAPACITY TABLES 82

PROCESSING INSTRUCTIONS..... 84

■ THE BENEFITS OF USING ALUMINIUM AS A CONDUCTOR MATERIAL

Choosing conductive metals for different industries and applications can be a challenge. Copper is often used in cables and wires because of its excellent conductivity and malleability. But it is relatively heavy and expensive compared to aluminium. Switching to aluminium, which is lighter and significantly less costly than copper, is a viable option in many cases. Using aluminium successfully is a matter of understanding the capabilities of this conductive metal and how to deal with the challenges it presents.

Copper, which is priced at 5800 EUR per ton, is currently more than twice as expensive as aluminium, priced at 2272 EUR per ton (as of 01/05/15). The greater availability of raw aluminium

compared to copper accounts for this significant difference in price. After oxygen and silicon, aluminium is the third most common element in the Earth's upper crust, while copper is ranked 25th in availability on the list of raw materials. Assessment of current prices is further reinforced by the volatility of the raw materials market.

Looking at the numbers from the last five years (2010-2014), copper prices fluctuated within a range from 4,700 to 7,650 EUR per ton. In 2004, the annual average value was still at 2,417 EUR per ton. No such fluctuation range exists in the aluminium sector, which allows for better material planning.

Development of annual average values

in Euro / 100kg

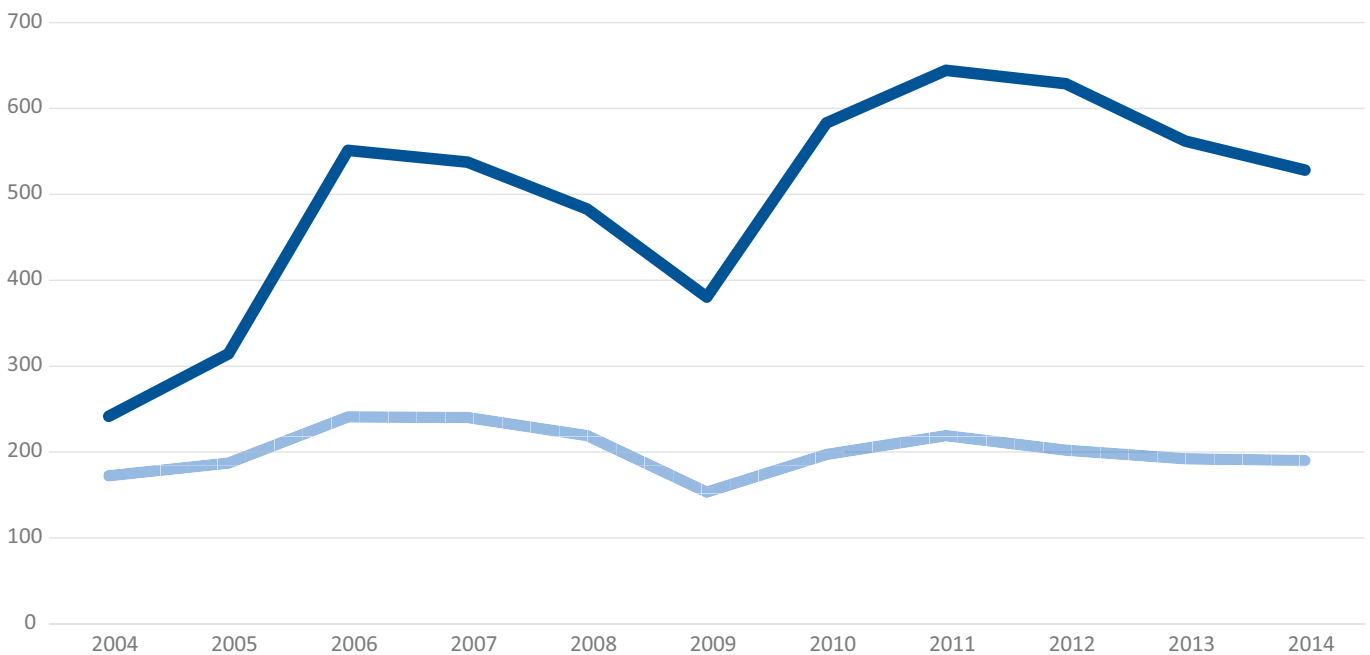
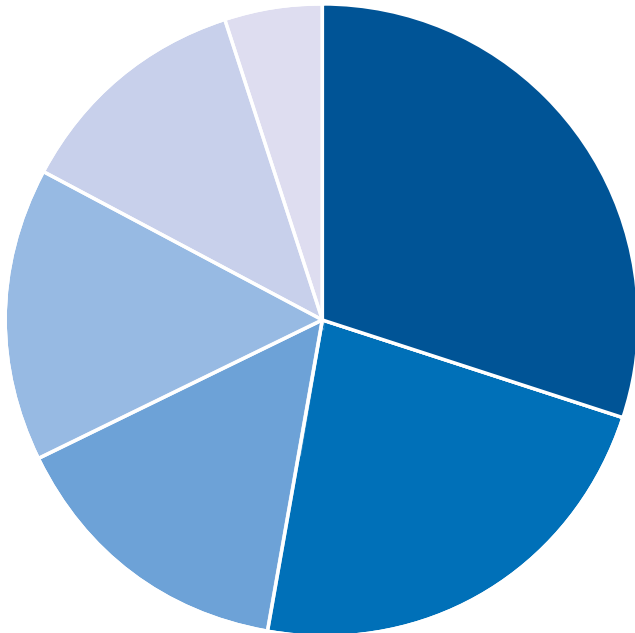

Chart by courtesy of Schutzvereinigung DEL-Notiz e.V.

■ Copper
■ Aluminium

6 facts about the HELUWIND® WK POWERLINE ALU



- Cost reduction
- Weight reduction
- Excellent flexibility
- Easy handling
- Lower risk of theft
- More stable metal prices

If aluminium is used as a conductor material, its lower conductivity requires a wire size that is approximately one-third larger than that of a copper wire. In the end however, the insulating material used with the wire plays a crucial role in performance and an aluminium wire can possess the same current carrying capacity as a H07RN-F copper wire. Aluminium's larger wire size would only be a disadvantage in applications requiring tight spacing, such as when installed in densely packed control boxes. The facts for aluminium speak for themselves when it comes to the issue of weight. As a raw material, aluminium is approximately 70 percent lighter in weight than copper. This can be helpful in the efforts of numerous application fields looking to reduce the weight of all components. Naturally, when used in

electrical cables, the lower weight makes them easier to install. High-voltage lines have long been made from aluminium; the lighter weight reduces the tensile force placed on wire and masts significantly. But even industries such as automotive manufacturing and the aeronautical industry are switching to aluminium wires. This is why entire wiring harnesses made of aluminium are already installed in the Airbus A380. Aluminium wires can be up to 60 percent lighter than comparable current-carrying copper wires.

Even for applications that require flexible cable connections, copper no longer needs to be the first choice. The HELUWIND® WK POWERLINE ALU series provides a fine-wired wiring programme, including connection technology.

■ FIELDS OF APPLICATION FOR ALUMINIUM CABLES



Rail Technology



Media Technology



Combined Heat

ALUM

Photovoltaic Plants

Plant Construction

Wind





and Power Plants

Industrial Plants

Substations

INIUM

Energy

Mobile Energy Supply

Energy Storage



ALUMINIUM CABLE RE/SE/SM 0,6/1KV





Technical data

- Power and control cable to DIN VDE 0276 part 603, HD 603 S1 and IEC 60502
- Insulation and sheath-compound of thermoplastic PVC
- **Temperature range**
flexing -5°C to +50°C
fixed installation -40°C to +70°C
- Permissible **operating temperature** at conductor +70°C
- Permissible **short circuit temperature** (short circuit duration max. 5 s)
≤ 300 mm² +160°C
> 300 mm² +140°C
- **Nominal voltage** U₀/U 0,6/1 kV
- **Test voltage** 4 kV
- Max. permissible **tensile stress** with cable grip at conductor 30 N/mm²
- **Current carrying capacity** to DIN VDE 0276 part 603, in normal operation table 14 and 15, under short circuit conditions table 17
- **Minimum bending radius**
single-core 15x cable Ø
multi-core 12x cable Ø
- **Caloric load values**
see Technical Informations

Cable structure

- Aluminium-conductor, to DIN VDE 0295 cl.1 or cl.2, single-wire or multi-wire, BS 6360 cl.1 or cl.2, IEC 60228 cl.1 or cl.2
- Core insulation of PVC compound type DIV4 to HD 603 S1
- Core identification to DIN VDE 0293-308, 0276 part 603
- Cores stranded in concentric layers
- Common core sheath
- Outer sheath of PVC compound type DMV5 to HD 603 S1
- Sheath colour black

Properties

- The materials used in manufacture are cadmium-free and contain no silicone and free from substances harmful to the wetting properties of lacquers

Tests

- PVC self-extinguishing and flame retardant acc. to DIN VDE 0482-332-1-2, DIN EN 60332-1-2, IEC 60332-1 (equivalent DIN VDE 0472 part 804 test method B)

Highest permissible voltage

- Direct current systems 1,8 kV
- Alternating current systems
 - Single-phase systems
both outer conductors insulated 1,4 kV
 - Single-phase systems
one outer conductor earthed 0,7 kV
- Three-phase systems 1,2 kV

Note

- re = round conductor, single-wire
- rm = round conductor, multi-wire
- se = sectional conductor, single-wire
- sm = sectional conductor, multi-wire
- J-version = with GN-YE conductor
- O-version = without GN-YE conductor
- AWG sizes are approximate equivalent values. The actual cross-section is in mm².

Application

Power cables for energy supply are installed in open air, in underground, in water, in concrete, indoors, in cable ducts, power stations, for industry and distribution boards as well as in subscriber networks, where mechanical damages are not be expected.

CE= The product is conformed with the EC Low-Voltage Directive 2006/95/EC.

No. cores x cross-sec. mm ²	Outer Ø app. mm	Alu weight kg / km	Weight app. kg / km	J type Part no.	AWG-No.	O type Part no.	AWG-No.
4 x 16	re 23,0	186,0	750,0	32301	6	-	6
4 x 25	re 26,0	290,0	950,0	32302	4	-	4
4 x 35	re 28,5	406,0	1120,0	32303	2	-	2
4 x 50	se 30,0	580,0	1151,0	32304	1	-	1
4 x 70	se 35,0	812,0	1549,0	32305	2/0	-	2/0
4 x 95	se 39,5	1102,0	2030,0	32306	3/0	-	3/0
4 x 95	sm 39,5	1102,0	2030,0	32177	3/0	-	3/0
4 x 120	se 44,0	1392,0	2400,0	32307	4/0	-	4/0
4 x 120	sm 44,0	1392,0	2400,0	32178	4/0	-	4/0
4 x 150	se 46,0	1740,0	3030,0	32308	300 kcmil	-	300 kcmil
4 x 150	sm 46,0	1740,0	3030,0	32179	300 kcmil	-	300 kcmil
4 x 185	se 51,0	2146,0	3650,0	32309	350 kcmil	-	350 kcmil
4 x 185	sm 51,0	2146,0	3650,0	32180	350 kcmil	-	350 kcmil
4 x 240	se 56,0	2784,0	4800,0	32310	500 kcmil	-	500 kcmil
4 x 240	sm 56,0	2784,0	4800,0	32181	500 kcmil	-	500 kcmil
4 x 300	se 64,0	3480,0	5596,0	32182	600 kcmil	-	600 kcmil
4 x 300	sm 64,0	3480,0	5596,0	32183	600 kcmil	-	600 kcmil

Continuation ▶

No. cores x cross-sec. mm ²		Outer Ø app. mm	Alu weight kg / km	Weight app. kg / km	J type Part no.	AWG-No.		O type Part no.	AWG-No.	
5 x 10	re	22,0	145,0	637,0	33275	8	-	33283	8	-
5 x 16	re	25,0	232,0	832,0	33276	6	-	33284	6	-
5 x 25	re	28,0	363,0	1175,0	33277	4	-	33285	4	-
5 x 35	re	31,0	508,0	1399,0	33278	2	-	33286	2	-
5 x 50	rm	35,0	725,0	1855,0	33279	1	-	33287	1	-
5 x 70	rm	40,0	1015,0	2351,0	33280	2/0	-	33288	2/0	-
5 x 95	rm	45,0	1378,0	3071,0	33281	3/0	-	33289	3/0	-
5 x 120	rm	49,0	1740,0	3631,0	33282	4/0	-	33290	4/0	-
5 x 150	rm	57,8	2175,0	4405,0	34041	300 kcmil	-	34042	300 kcmil	-
5 x 185	rm	61,5	2683,0	5420,0	34043	350 kcmil	-	34044	350 kcmil	-
5 x 240	rm	70,0	3480,0	6860,0	34045	500 kcmil	-	34046	500 kcmil	-

No. cores x cross-sec. mm ²		Outer Ø app. mm	Alu weight kg / km	Weight app. kg / km	J type Part no.	AWG-No.		O type Part no.	AWG-No.	
1 x 35	re	13,0	102,0	240,0	32328	2	-	32311	2	-
1 x 50	re	15,0	145,0	360,0	32329	1	-	32312	1	-
1 x 70	rm	16,5	203,0	410,0	32390	2/0	-	32313	2/0	-
1 x 95	rm	19,0	276,0	570,0	32391	3/0	-	32314	3/0	-
1 x 120	rm	20,5	348,0	691,0	32392	4/0	-	32315	4/0	-
1 x 150	rm	22,5	435,0	804,0	32393	300 kcmil	-	32321	300 kcmil	-
1 x 185	rm	25,0	537,0	979,0	32394	350 kcmil	-	32322	350 kcmil	-
1 x 240	rm	28,0	696,0	1253,0	32395	500 kcmil	-	32323	500 kcmil	-
1 x 300	rm	30,0	870,0	1395,0	32396	600 kcmil	-	32324	600 kcmil	-
1 x 400	rm	34,0	1160,0	1890,0	32397	750 kcmil	-	32325	750 kcmil	-
1 x 500	rm	38,0	1450,0	2600,0	32398	1000 kcmil	-	32326	1000 kcmil	-
1 x 630	rm	43,0	1827,0	2780,0	32399	1250 kcmil	-	32327	1250 kcmil	-

Dimensions and specifications may be changed without prior notice. (RQ01)

NAY2Y power cable, 0,6/1kV, with PE-outer sheath



Technical data

- Power and control cable to DIN VDE 0276 part 603, HD 603 S1 and IEC 60502
- **Temperature range**
flexing -5°C to +50°C
fixed installation -40°C to +70°C
- Permissible **operating temperature** at conductor +70°C
- Permissible **short circuit temperature** (short circuit duration max. 5 s) +160°C
- **Nominal voltage** U_0/U 0,6/1 kV
- **Test voltage** 4 kV
- Max. permissible **tensile stress** with cable grip at conductor 30 N/mm²
- **Minimum bending radius** 12x cable Ø

Cable structure

- Aluminium-conductor, to DIN VDE 0295 cl.1, single-wire, BS 6360 cl.1, IEC 60228 cl.1
- Core insulation of PVC
- Core identification GN-YE, BN, BK, GY
- Cores stranded in concentric layers
- Common core sheath
- Outer sheath of PE
- Sheath colour black

Properties

- outer sheath PE of not self-extinguishing and flame retardant
- The materials used in manufacture are cadmium-free and contain no silicone and free from substances harmful to the wetting properties of lacquers

Highest permissible voltage

- Direct current systems 1,8 kV
- Alternating current systems
 - Single-phase systems both outer conductors insulated 1,4 kV
 - Single-phase systems one outer conductor earthed 0,7 kV
- Three-phase systems 1,2 kV

Note

- re = round conductor, single-wire
- se = sectional conductor, single-wire
- AWG sizes are approximate equivalent values. The actual cross-section is in mm².

Application

Power cables for energy supply are installed in open air, in underground, in water, in concrete, indoors, in cable ducts, power stations, for industry and distribution boards as well as in subscriber networks. Usable in extreme working conditions due to the robust PE outer sheath.

☞ The product is conformed with the EC Low-Voltage Directive 2006/95/EC.

Part no.	No. cores x cross-sec. mm ²	Outer Ø app. mm	Alu weight kg / km	Weight app. kg / km	AWG-No.
31129	4 x 25 re	26,0	290,0	970,0	4
31139	4 x 35 re	28,0	406,0	1145,0	2
31149	4 x 50 se	30,0	580,0	1184,0	1
31159	4 x 70 se	33,0	812,0	1578,0	2/0
31169	4 x 95 se	38,0	1102,0	2186,0	3/0
31179	4 x 120 se	42,0	1382,0	2501,0	4/0
31189	4 x 150 se	45,0	1740,0	3180,0	300 kcmil
31199	4 x 185 se	51,0	2146,0	3807,0	350 kcmil
31209	4 x 240 se	55,0	2784,0	4996,0	500 kcmil

Dimensions and specifications may be changed without prior notice. (RQ01)



Technical data

- Power and control cable to DIN VDE 0276 Part 603, HD 603 S1 and IEC 60502
- **Temperature range**
flexing -5°C to +50°C
fixed installation -40°C to +70°C
- Permissible **operating temperature** at conductor +90°C
- Permissible **short circuit temperature** (short circuit duration max. 5 s) +250°C
- **Nominal voltage** U₀/U 0,6/1 kV
- **Test voltage** 4 kV
- Max. permissible **tensile stress** with cable grip at conductor 30 N/mm²
- **Minimum bending radius**
single-core 15x cable Ø
multi-core 12x cable Ø

Cable structure

- Aluminium-conductor to DIN VDE 0295 cl.1 or cl.2, single-wire or multi-wire, BS 6360 cl.1 or cl.2, IEC 60228 cl.1 or cl.2
- Core insulation of cross-linked polyethylene (XLPE) compound type DIX3 to HD 603 S1
- Core identification to DIN VDE 0293-308, 0276 part 603
- Cores stranded in concentric layers
- Outer sheath of PVC compound type DMV6/DMP2 to HD 603 S1
- Sheath colour black

Properties

- The materials used in manufacture are cadmium-free and contain no silicone and free from substances harmful to the wetting properties of lacquers

Tests

- self-extinguishing and flame retardant acc. to DIN VDE 0482-332-1-2, DIN EN 60332-1-2, IEC 60332-1 (equivalent DIN VDE 0472 part 804 test method B)

Highest permissible voltage

- Direct current systems 1,8 kV
- Alternating current systems
 - Single-phase systems both outer conductors insulated 1,4 kV
 - Single-phase systems one outer conductor earthed 0,7 kV
- Three-phase systems 1,2 kV

Note

- re = round conductor, single-wire
- rm = round conductor, multi-wire
- se = sectional conductor, single-wire
- J-version = with GN-YE conductor
- O-version = without GN-YE conductor
- AWG sizes are approximate equivalent values. The actual cross-section is in mm².

Application

Power distribution cables for use in underground, in water, outdoors, in concrete, indoors, in cable ducts, for power stations, industrial applications and switching systems, as well as in local networks if no mechanical damage is expected. Respecting the permissible operating temperature at the conductor of +90°C permits a higher current carrying capacity than PVC insulated power distribution cables.

CE= The product is conformed with the EC Low-Voltage Directive 2006/95/EC.

No. cores x cross-sec. mm ²		Outer Ø app. mm	Alu weight kg / km	Weight app. kg / km	J type Part no.	AWG-No.		O type Part no.	AWG-No.	
1 x 16	re	11,5	47,0	98,0	33113	6	-	33125	6	-
1 x 25	re	12,5	73,0	150,0	33114	4	-	33126	4	-
1 x 35	re	13,5	102,0	241,0	33115	2	-	33127	2	-
1 x 50	rm	15,5	145,0	357,0	33116	1	-	33128	1	-
1 x 70	rm	17,0	203,0	409,0	33117	2/0	-	33129	2/0	-
1 x 95	rm	19,0	276,0	570,0	33118	3/0	-	33130	3/0	-
1 x 120	rm	20,5	348,0	590,0	33119	4/0	-	33131	4/0	-
1 x 150	rm	23,0	435,0	804,0	33120	300 kcmil	-	33132	300 kcmil	-
1 x 185	rm	25,5	537,0	978,0	33121	350 kcmil	-	33133	350 kcmil	-
1 x 240	rm	28,5	696,0	1253,0	33122	500 kcmil	-	33134	500 kcmil	-
1 x 300	rm	30,0	870,0	1394,0	33123	600 kcmil	-	33135	600 kcmil	-
1 x 400	rm	34,0	1160,0	1890,0	33124	750 kcmil	-	33136	750 kcmil	-
4 x 16	re	21,5	186,0	750,0	33137	6	-	33147	6	-
4 x 25	re	26,0	290,0	950,0	33138	4	-	33148	4	-
4 x 35	re	27,5	406,0	1120,0	33139	2	-	33149	2	-
4 x 50	se	30,0	580,0	1251,0	33140	1	-	33150	1	-
4 x 70	se	34,0	812,0	1548,0	33141	2/0	-	33151	2/0	-
4 x 95	se	39,0	1102,0	2030,0	33142	3/0	-	33152	3/0	-
4 x 120	se	42,5	1392,0	2400,0	33143	4/0	-	33153	4/0	-
4 x 150	se	47,5	1740,0	3030,0	33144	300 kcmil	-	33154	300 kcmil	-
4 x 185	se	52,0	2146,0	3650,0	33145	350 kcmil	-	33155	350 kcmil	-
4 x 240	se	58,0	2784,0	4800,0	33146	500 kcmil	-	33156	500 kcmil	-

Dimensions and specifications may be changed without prior notice. (RQ02)

HELUWIND® WK (N)A2XH 0,6/1kV, halogen-free



Technical data

- **Temperature range**
fixed installation -40°C to +90°C
during assembly -5°C to +50°C
- **Operating temperature at conductor**
max. +90°C
- **Nominal voltage**
U₀/U 0,6/1 V
- **Test voltage**
4 kV
- **Approvals**
production in according to VDE standards,
CE compliant
- **Minimum bending radius**
15 x cable Ø
- **Flame test**
acc. to DIN VDE 0482 part 266-2,
BS 4066 part 3, EN 50266-2,
IEC 60332-3-24 (equivalent
DIN VDE 0472 part 804 cat. C)
- **Smoke density**
acc. to DIN VDE 0482 part 268, HD 606,
EN 50268-12, IEC 61034-1-2,
BS 7622 Teil 12 (equivalent
DIN VDE 0472 Teil 816)
- **Corrosivity of combustion gases**
acc. to VDE 0482 Teil 267,
DIN EN 50267-2-2, IEC 60754-2
(equivalent DIN VDE 0472 part 813)
- **Halogen free**
acc. to DIN VDE 0482 part 267,
DIN EN 50267-2-1, IEC 60754-1
(equivalent DIN VDE 0472 part 815)

Cable structure

- ALU conductors, stranded conductors acc. to IEC 60228 Cl. 2
- core insulation cross-linked PE
- Core identification black
- Sheath thermoplastic polymer
- black sheath

Properties

- Halogen-free
- UV resistant

Note

Other diameters, part-no. and prices on request. Please contact us with your individual requirements via fax +49 7150 9209 5135.

Application

The HELUWIND® WK series was specifically designed for wind power applications. We supply the leading wind turbine manufacturers with our cables. **CE** = The product is conformed with the EC Low-Voltage Directive 2006/95/EC.

Part no.	No. cores x cross-sec. mm ²	AWG no.	Outer-Ø approx. mm	AL weight kg/km	Weight approx. kg/km	Price EUR/ 100m AL 0,-
705031	1 x 185	350 kcmil	22,0	537,0	1100,0	a.A.
705032	1 x 240	500 kcmil	24,2	696,0	1208,0	a.A.

Part no.	No. cores x cross-sec. mm ²	AWG no.	Outer-Ø approx. mm	AL weight kg/km	Weight approx. kg/km	Price EUR/ 100m AL 0,-
705033	1 x 300	600 kcmil	26,9	870,0	1342,0	a.A.
705034	1 x 400	750 kcmil	29,9	1160,0	1843,0	a.A.

Dimensions and specifications may be changed without prior notice.



Technical data

- Power and control cable to DIN VDE 0276 part 603, HD 603 S1 and IEC 60502
- **Temperature range**
flexing -5°C to +50°C
fixed installation -40°C to +70°C
- Permissible **operating temperature** at conductor +70°C
- Permissible **short circuit temperature** (short circuit duration max. 5 s) +160°C
- **Nominal voltage** U_0/U 0,6/1 kV
- **Test voltage** 4 kV
- Max. permissible **tensile stress** with cable grip at conductor 30 N/mm²
- **Minimum bending radius** 12x cable \varnothing

Cable structure

- Aluminium-conductor, to DIN VDE 0295 cl.1 or cl.2, single-wire or multi-wire, BS 6360 cl.1 or cl.2, IEC 60228 cl.1 or cl.2
- Core insulation of PVC compound type DIV4 to HD 603 S1
- Core identification DIN VDE 0293-308
- Cores stranded concentrically
- Filling compound
- Concentric conductor (Ceander), inner layer of corrugated copper wires, outer layer with copper tape
- Outer sheath of PVC compound type DMV5 to HD 603 S1
- Sheath colour black

Properties

- The materials used in manufacture are cadmium-free and contain no silicone and free from substances harmful to the wetting properties of lacquers

Tests

- PVC self-extinguishing and flame retardant acc. to DIN VDE 0482-332-1-2, DIN EN 60332-1-2, IEC 60332-1 (equivalent DIN VDE 0472 part 804 test method B)

Highest permissible voltage

- Direct current systems 1,8 kV
- Alternating current systems
 - Single-phase systems both outer conductors insulated 1,4 kV
 - Single-phase systems one outer conductor earthed 0,7 kV
- Three-phase systems 1,2 kV with concentric conductor and a cross-section from 240 mm² 3,6 kV

Note

- re = round conductor, single-wire
- rm = round conductor, multi-wire
- sm = sectional conductor, multi-wire
- AWG sizes are approximate equivalent values. The actual cross-section is in mm².

Application

Power distribution cables, preferably used for underground installation, primarily in local networks, for industrial applications and switching systems, power stations. Wherever increased electrical and mechanical protection are required. Installation in water, outdoors, in concrete, indoors and in cable ducts. The concentric conductor (C) can be used as a PE or PEN conductor or as a screen. The corrugated design (Ceander) of the concentric conductor permits any number of cable junctions during assembly, without any conductors having to be cut. This ensures an optimal reliability.

☞ The product is conformed with the EC Low-Voltage Directive 2006/95/EC.

Part no.	No. cores x cross-sec. mm ²	Outer \varnothing app. mm	Cop. weight kg / km	Alu weight kg / km	Weight app. kg / km	AWG-No.
36009	3 x 10 re / 10	20,2	88,0	87,0	603,0	8
36010	3 x 16 re / 16	22,3	125,0	139,0	754,0	6
36011	3 x 25 re / 25	25,5	170,0	218,0	1043,0	4
36012	3 x 25 rm / 16	26,6	125,0	218,0	1046,0	4
36013	3 x 25 rm / 25	26,6	170,0	218,0	1101,0	4
36014	3 x 35 re / 35	27,6	240,0	305,0	1243,0	2
36015	3 x 35 sm / 16	26,4	125,0	305,0	1002,0	2
36016	3 x 35 sm / 35	26,4	240,0	305,0	1107,0	2
36017	3 x 50 sm / 25	29,4	170,0	435,0	1283,0	1
36018	3 x 70 sm / 35	32,6	240,0	609,0	1633,0	2/0
36019	3 x 70 sm / 70	33,4	475,0	609,0	1838,0	2/0
36020	3 x 95 sm / 50	38,1	340,0	827,0	2136,0	3/0
36021	3 x 95 sm / 95	38,1	640,0	827,0	2449,0	3/0
36022	3 x 120 sm / 50	40,8	340,0	1044,0	2517,0	4/0
36023	3 x 120 sm / 70	40,8	475,0	1044,0	2612,0	4/0
36024	3 x 150 sm / 70	44,9	475,0	1305,0	3019,0	300 kcmil
36025	3 x 150 sm / 150	45,5	1000,0	1305,0	3517,0	300 kcmil
36026	3 x 185 sm / 70	49,8	475,0	1610,0	3741,0	350 kcmil
36027	3 x 185 sm / 95	49,8	640,0	1610,0	3895,0	350 kcmil
36028	3 x 240 sm / 70	55,4	475,0	2088,0	4539,0	500 kcmil
36029	3 x 240 sm / 120	55,8	800,0	2088,0	4838,0	500 kcmil
36030	3 x 240 sm / 240	56,0	1665,0	2088,0	5611,0	500 kcmil
32840	4 x 16 re / 16	23,9	125,0	186,0	801,0	6
32841	4 x 25 re / 16	28,9	125,0	290,0	1243,0	4
32842	4 x 35 re / 16	30,3	125,0	406,0	1282,0	2
32843	4 x 50 sm / 25	34,8	170,0	580,0	1689,0	1
32844	4 x 70 sm / 35	38,6	240,0	814,0	2074,0	2/0
32845	4 x 95 sm / 50	44,4	340,0	1102,0	2779,0	3/0
32846	4 x 120 sm / 70	48,7	475,0	1392,0	3365,0	4/0
32847	4 x 150 sm / 70	53,3	475,0	1740,0	3813,0	300 kcmil
32848	4 x 185 sm / 95	59,1	640,0	2146,0	4877,0	350 kcmil
32849	4 x 240 sm / 120	66,0	800,0	2784,0	6017,0	500 kcmil

Dimensions and specifications may be changed without prior notice.



ALUMINIUM CABLE RM 6-30KV



2XS(F)2Y 18/30KV

NA2XS_Y 6/10kV, 12/20kV, 18/30kV XLPE-insulated, alu-conductor, single core, screened, PVC-sheath



Technical data

- XLPE-insulated power cables to DIN VDE 0276 part 620, HD 620 S2 and IEC 60502
- **Temperature range**
during installation up to -5°C
- **Operating temperature**
max. +90°C
- **Short circuit temperature**
+250°C (short circuit duration max. 5 s)
- **Nominal voltages**
U₀/U 6/10 kV, 12/20 kV, 18/30 kV
- **Operating voltages**
for 6/10 kV = max. 12 kV
for 12/20 kV = max. 24 kV
for 18/30 kV = max. 36 kV
- **Test voltages**
for 6/10 kV = 15 kV
for 12/20 kV = 30 kV
for 18/30 kV = 45 kV
- **Minimum bending radius**
15x cable Ø
- **Power ratings**
see Technical Informations

Cable structure

- Aluminium-conductor, to DIN VDE 0295 cl.2, multi-wire, BS 6360 cl.2, IEC 60228 cl.2
- Inner semi-conducting coating
- Core insulation of cross-linked polyethylene (XLPE), compound type DIX8 to HD 620 S2
- Outer extrusion of semi-conducting coating spliced with the insulation
- Wrapping of conductive material
- Screen: Braiding of copper wires with one or two tapes applied helically
- Wrapping
- Outer sheath of PVC compound type DMV6 to HD 620 S2
- Sheath colour red

Properties

- The materials used in manufacture are cadmium-free and contain no silicone and free from substances harmful to the wetting properties of lacquers
- ### Tests
- self-extinguishing and flame retardant acc. to DIN VDE 0482-332-1-2, DIN EN 60332-1-2, IEC 60332-1 (equivalent DIN VDE 0472 part 804 test method B)
- ### Installation notes
- To guarantee an optimum on operating reliability the extruded semi-conductive layer is spliced with the insulation for long duration. For this reason we recommend a peeling tool for installation

Note

- rm = round conductor, multi-wire
- Further dimensions available on request.
- AWG sizes are approximate equivalent values. The actual cross-section is in mm².

Application

Suitable for installation mostly for power supply stations, in indoors and in cable ducts, outdoor with protected laying, underground and in water as well as for installation on cable trays for industries, switch-boards and power stations. Due to the good laying characteristic, this can also be laid easily in difficult line guideways.

The inner conducting layer between the conductor and the XLPE insulation and the firmly bonded outer conducting layer on the XLPE insulation assures a construction free of partial discharges with high operational reliability.

Part no.	No.cores x cross-sec. mm ²	Operation voltage max.	Nominal voltage kV	Insulation thickness mm	Sheath thickness Nominal value mm	Outer Ø min. - max. mm	Cop. weight kg / km	Alu weight kg / km	Weight app. kg / km	AWG-No.
32440	1 x 50 rm / 16	12	6 / 10	3,4	2,5	24,0 - 29,0	182,0	145,0	780,0	1
32441	1 x 70 rm / 16	12	6 / 10	3,4	2,5	26,0 - 31,0	182,0	203,0	875,0	2/0
32442	1 x 95 rm / 16	12	6 / 10	3,4	2,5	26,0 - 32,0	182,0	276,0	990,0	3/0
32443	1 x 120 rm / 16	12	6 / 10	3,4	2,5	28,0 - 34,0	182,0	348,0	1110,0	4/0
32444	1 x 150 rm / 16	12	6 / 10	3,4	2,5	29,0 - 35,0	182,0	435,0	1240,0	300 kcmil
32445	1 x 150 rm / 25	12	6 / 10	3,4	2,5	29,0 - 35,0	283,0	435,0	1310,0	300 kcmil
32446	1 x 185 rm / 16	12	6 / 10	3,4	2,5	31,0 - 37,0	182,0	537,0	1405,0	350 kcmil
32447	1 x 185 rm / 25	12	6 / 10	3,4	2,5	31,0 - 37,0	283,0	537,0	1460,0	350 kcmil
32448	1 x 240 rm / 16	12	6 / 10	3,4	2,5	33,0 - 39,0	182,0	696,0	1615,0	500 kcmil
32449	1 x 240 rm / 25	12	6 / 10	3,4	2,5	33,0 - 39,0	283,0	696,0	1660,0	500 kcmil
32450	1 x 300 rm / 25	12	6 / 10	3,4	2,5	36,0 - 41,0	283,0	870,0	1910,0	600 kcmil
32451	1 x 400 rm / 35	12	6 / 10	3,4	2,5	40,0 - 45,0	394,0	1160,0	2315,0	750 kcmil
32452	1 x 500 rm / 35	12	6 / 10	3,4	2,5	43,0 - 48,0	394,0	1450,0	2750,0	1000 kcmil
32453	1 x 50 rm / 16	24	12 / 20	5,5	2,5	28,0 - 33,0	182,0	145,0	950,0	1
32454	1 x 70 rm / 16	24	12 / 20	5,5	2,5	30,0 - 35,0	182,0	203,0	1110,0	2/0
32455	1 x 95 rm / 16	24	12 / 20	5,5	2,5	31,0 - 36,0	182,0	276,0	1220,0	3/0
32456	1 x 120 rm / 16	24	12 / 20	5,5	2,5	32,0 - 38,0	182,0	348,0	1310,0	4/0
32457	1 x 150 rm / 16	24	12 / 20	5,5	2,5	33,0 - 39,0	182,0	435,0	1460,0	300 kcmil
32458	1 x 150 rm / 25	24	12 / 20	5,5	2,5	33,0 - 39,0	283,0	435,0	1520,0	300 kcmil
32459	1 x 185 rm / 16	24	12 / 20	5,5	2,5	35,0 - 41,0	182,0	537,0	1660,0	350 kcmil
32460	1 x 185 rm / 25	24	12 / 20	5,5	2,5	35,0 - 41,0	283,0	537,0	1720,0	350 kcmil
32461	1 x 240 rm / 16	24	12 / 20	5,5	2,5	38,0 - 44,0	182,0	696,0	1860,0	500 kcmil
32462	1 x 240 rm / 25	24	12 / 20	5,5	2,5	38,0 - 44,0	283,0	696,0	1910,0	500 kcmil
32463	1 x 300 rm / 25	24	12 / 20	5,5	2,5	40,0 - 46,0	283,0	870,0	2220,0	600 kcmil
32464	1 x 400 rm / 35	24	12 / 20	5,5	2,5	43,0 - 49,0	394,0	1160,0	2620,0	750 kcmil
32465	1 x 500 rm / 35	24	12 / 20	5,5	2,5	46,0 - 52,0	394,0	1450,0	3030,0	1000 kcmil
32466	1 x 50 rm / 16	36	18 / 30	8	2,5	32,0 - 38,0	182,0	145,0	1260,0	1
32467	1 x 70 rm / 16	36	18 / 30	8	2,5	34,0 - 40,0	182,0	203,0	1360,0	2/0

Continuation ▶

NA2XS_Y 6/10kV, 12/20kV, 18/30kV XLPE-insulated, alu-conductor, single core, screened, PVC-sheath



Part no.	No. cores x cross-sec. mm ²	Operation voltage max.	Nominal voltage kV	Insulation thickness mm	Sheath thickness Nominal value mm	Outer Ø min. - max. mm	Cop. weight kg / km	Alu weight kg / km	Weight app. kg / km	AWG-No.
32468	1 x 95 rm / 16	36	18 / 30	8	2,5	35,0 - 41,0	182,0	276,0	1510,0	3/0
32469	1 x 120 rm / 16	36	18 / 30	8	2,5	37,0 - 43,0	182,0	348,0	1610,0	4/0
32470	1 x 150 rm / 16	36	18 / 30	8	2,5	38,0 - 44,0	182,0	435,0	1760,0	300 kcmil
32471	1 x 150 rm / 25	36	18 / 30	8	2,5	38,0 - 44,0	283,0	435,0	1810,0	300 kcmil
32472	1 x 185 rm / 16	36	18 / 30	8	2,5	40,0 - 46,0	182,0	537,0	1960,0	350 kcmil
32473	1 x 185 rm / 25	36	18 / 30	8	2,5	40,0 - 46,0	283,0	537,0	2020,0	350 kcmil
32474	1 x 240 rm / 16	36	18 / 30	8	2,5	42,0 - 48,0	182,0	696,0	2210,0	500 kcmil
32475	1 x 240 rm / 25	36	18 / 30	8	2,5	42,0 - 48,0	283,0	696,0	2260,0	500 kcmil
32476	1 x 300 rm / 25	36	18 / 30	8	2,5	45,0 - 51,0	283,0	870,0	2560,0	600 kcmil
32477	1 x 400 rm / 35	36	18 / 30	8	2,5	48,0 - 54,0	394,0	1160,0	2960,0	750 kcmil
32478	1 x 500 rm / 35	36	18 / 30	8	2,5	51,0 - 57,0	394,0	1450,0	3460,0	1000 kcmil

Dimensions and specifications may be changed without prior notice. (RQ03)

NA2XS2Y 6/10kV, 12/20kV, 18/30kV XLPE-insulated,

Alu-conductor, single core, screened, PE-sheath



RoHS

Technical data

- XLPE-insulated power cables to DIN VDE 0276 part 620, HD 620 S2 and IEC 60502
- **Temperature range** during installation up to -20°C
- **Operating temperature** max. +90°C
- **Short circuit temperature** +250°C (short circuit duration max. 5 s)
- **Nominal voltages** U₀/U 6/10 kV, 12/20 kV, 18/30 kV
- **Operating voltages** for 6/10 kV = max. 12 kV for 12/20 kV = max. 24 kV for 18/30 kV = max. 36 kV
- **Test voltages** for 6/10 kV = 15 kV for 12/20 kV = 30 kV for 18/30 kV = 45 kV
- **Minimum bending radius** 15x cable Ø
- **Power ratings** see Technical Informations

Cable structure

- Aluminium-conductor, to DIN VDE 0295 cl.2, multi-wire, BS 6360 cl.2, IEC 60228 cl.2
- Inner semi-conducting coating
- Core insulation of cross-linked polyethylene (XLPE), compound type DIX8 to HD 620 S2
- Outer extrusion of semi-conducting coating spliced with the insulation
- Wrapping of conductive material
- Screen: Braiding of copper wires with one or two tapes applied helically
- Wrapping
- Outer sheath of PE compound type DMP2 to HD 620 S2
- Sheath colour black

Properties

- The materials used in manufacture are cadmium-free and contain no silicone and free from substances harmful to the wetting properties of lacquers
- **Installation notes** To guarantee an optimum on operating reliability the extruded semi-conductive layer is spliced with the insulation for long duration. For this reason we recommend a peeling tool for installation.

Note

- rm = round conductor, multi-wire
- Further dimensions available on request.
- AWG sizes are approximate equivalent values. The actual cross-section is in mm².

Application

Suitable for indoor installation and in cable ducts, outdoors, underground and in water as well as for installation on cable trays for industries, switch-boards and power stations. The PE-outer sheath is resistant to high mechanical stress for laying the cables. This PE sheath is not flame retardant acc. to DIN EN 60332-1-2.

The inner conducting layer between the conductor and the XLPE insulation and the firmly bonded outer conducting layer on the XLPE insulation assures a construction free of partial discharges with high operational reliability.

Part no.	No.cores x cross-sec. mm ²	Operation voltage max.	Nominal voltage kV	Insulation thickness mm	Sheath thickness Nominal value mm	Outer Ø min. - max. mm	Cop. weight kg / km	Alu weight kg / km	Weight app. kg / km	AWG-No.
32520	1 x 50 rm / 16	12	6 / 10	3,4	2,5	24,0 - 29,0	182,0	145,0	710,0	1
32521	1 x 70 rm / 16	12	6 / 10	3,4	2,5	26,0 - 31,0	182,0	203,0	790,0	2/0
32522	1 x 95 rm / 16	12	6 / 10	3,4	2,5	26,0 - 32,0	182,0	276,0	920,0	3/0
32523	1 x 120 rm / 16	12	6 / 10	3,4	2,5	28,0 - 34,0	182,0	348,0	990,0	4/0
32524	1 x 150 rm / 16	12	6 / 10	3,4	2,5	29,0 - 35,0	182,0	435,0	1110,0	300 kcmil
32525	1 x 150 rm / 25	12	6 / 10	3,4	2,5	29,0 - 35,0	283,0	435,0	1220,0	300 kcmil
32526	1 x 185 rm / 16	12	6 / 10	3,4	2,5	31,0 - 37,0	182,0	537,0	1260,0	350 kcmil
32527	1 x 185 rm / 25	12	6 / 10	3,4	2,5	33,0 - 39,0	283,0	537,0	1370,0	350 kcmil
32528	1 x 240 rm / 16	12	6 / 10	3,4	2,5	33,0 - 39,0	182,0	696,0	1480,0	500 kcmil
32529	1 x 240 rm / 25	12	6 / 10	3,4	2,5	33,0 - 39,0	283,0	696,0	1530,0	500 kcmil
32530	1 x 300 rm / 25	12	6 / 10	3,4	2,5	36,0 - 41,0	283,0	870,0	1820,0	600 kcmil
32531	1 x 400 rm / 35	12	6 / 10	3,4	2,5	40,0 - 45,0	394,0	1160,0	2220,0	750 kcmil
32532	1 x 500 rm / 35	12	6 / 10	3,4	2,5	43,0 - 48,0	394,0	1450,0	2570,0	1000 kcmil
32533	1 x 50 rm / 16	24	12 / 20	5,5	2,5	28,0 - 33,0	182,0	145,0	890,0	1
32534	1 x 70 rm / 16	24	12 / 20	5,5	2,5	30,0 - 35,0	182,0	203,0	970,0	2/0
32535	1 x 95 rm / 16	24	12 / 20	5,5	2,5	31,0 - 36,0	182,0	276,0	1120,0	3/0
32536	1 x 120 rm / 16	24	12 / 20	5,5	2,5	32,0 - 38,0	182,0	348,0	1210,0	4/0
32537	1 x 150 rm / 16	24	12 / 20	5,5	2,5	33,0 - 39,0	182,0	435,0	1370,0	300 kcmil
32538	1 x 150 rm / 25	24	12 / 20	5,5	2,5	33,0 - 39,0	283,0	435,0	1420,0	300 kcmil
32539	1 x 185 rm / 16	24	12 / 20	5,5	2,5	35,0 - 41,0	182,0	537,0	1530,0	350 kcmil
32540	1 x 185 rm / 25	24	12 / 20	5,5	2,5	35,0 - 41,0	283,0	537,0	1570,0	350 kcmil
32541	1 x 240 rm / 16	24	12 / 20	5,5	2,5	38,0 - 44,0	182,0	696,0	1720,0	500 kcmil
32542	1 x 240 rm / 25	24	12 / 20	5,5	2,5	38,0 - 44,0	283,0	696,0	1830,0	500 kcmil
32543	1 x 300 rm / 25	24	12 / 20	5,5	2,5	40,0 - 46,0	283,0	870,0	2070,0	600 kcmil
32544	1 x 400 rm / 35	24	12 / 20	5,5	2,5	43,0 - 49,0	394,0	1160,0	2460,0	750 kcmil
32545	1 x 500 rm / 35	24	12 / 20	5,5	2,5	46,0 - 52,0	394,0	1450,0	2890,0	1000 kcmil
33078	1 x 630 rm / 35	24	12 / 20	5,5	2,5	47,0 - 53,0	394,0	1827,0	3370,0	1250 kcmil
32546	1 x 50 rm / 16	36	18 / 30	8	2,5	32,0 - 38,0	182,0	145,0	1120,0	1

Continuation ▶

NA2XS2Y 6/10kV, 12/20kV, 18/30kV XLPE-insulated, Alu-conductor, single core, screened, PE-sheath



Part no.	No. cores x cross-sec. mm ²	Operation voltage max.	Nominal voltage kV	Insulation thickness mm	Sheath thickness Nominal value mm	Outer Ø min. - max. mm	Cop. weight kg / km	Alu weight kg / km	Weight app. kg / km	AWG-No.
32547	1 x 70 rm / 16	36	18 / 30	8	2,5	34,0 - 40,0	182,0	203,0	1270,0	2/0
32548	1 x 95 rm / 16	36	18 / 30	8	2,5	35,0 - 41,0	182,0	276,0	1380,0	3/0
32549	1 x 120 rm / 16	36	18 / 30	8	2,5	37,0 - 43,0	182,0	348,0	1530,0	4/0
32550	1 x 150 rm / 25	36	18 / 30	8	2,5	38,0 - 44,0	283,0	435,0	1720,0	300 kcmil
32551	1 x 185 rm / 25	36	18 / 30	8	2,5	40,0 - 46,0	283,0	537,0	1860,0	350 kcmil
32552	1 x 240 rm / 25	36	18 / 30	8	2,5	42,0 - 48,0	283,0	696,0	2110,0	500 kcmil
32553	1 x 300 rm / 25	36	18 / 30	8	2,5	45,0 - 51,0	283,0	870,0	2370,0	600 kcmil
32554	1 x 400 rm / 35	36	18 / 30	8	2,5	48,0 - 54,0	394,0	1160,0	2820,0	750 kcmil
32555	1 x 500 rm / 35	36	18 / 30	8	2,5	51,0 - 57,0	394,0	1450,0	3280,0	1000 kcmil
32999	1 x 630 rm / 35	36	18 / 30	8	2,5	52,0 - 59,0	394,0	1827,0	3770,0	1250 kcmil

Dimensions and specifications may be changed without prior notice. (RQ03)

NA2XS(F)2Y 6/10kV, 12/20kV, 18/30kV XLPE-insulated, alu-conductor, single core, longitudinally water-tight, screened, PE-sheath



Technical data

- XLPE-insulated power cables to DIN VDE 0276 part 620, HD 620 S2 and IEC 60502
- **Temperature range** during installation up to -20°C
- **Operating temperature** max. +90°C
- **Short circuit temperature** +250°C (short circuit duration max. 5 s)
- **Nominal voltages** U₀/U 6/10 kV, 12/20 kV, 18/30 kV
- **Operating voltages** for 6/10 kV = max. 12 kV for 12/20 kV = max. 24 kV for 18/30 kV = max. 36 kV
- **Test voltages** for 6/10 kV = 15 kV for 12/20 kV = 30 kV for 18/30 kV = 45 kV
- **Minimum bending radius** 15x cable Ø
- **Power ratings** see Technical Informations

Cable structure

- Aluminium-conductor, to DIN VDE 0295 cl.2, multi-wire, BS 6360 cl.2, IEC 60228 cl.2
- Inner semi-conducting coating
- Core insulation of cross-linked polyethylene (XLPE), compound type DIX8 to HD 620 S2
- Outer extrusion of semi-conducting coating spliced with the XLPE-insulation
- Longitudinally water-tight, conductive wrapping
- Screen: Braiding of copper wires with one or two tapes applied helically
- Longitudinally water-tight wrapping
- Outer sheath of PE compound type DMP2 to HD 620 S2
- Sheath colour black
- Sheath thickness voltage 2,5 mm

Properties

- The materials used in manufacture are cadmium-free and contain no silicone and free from substances harmful to the wetting properties of lacquers
- **Installation notes** To guarantee an optimum on operating reliability the extruded semi-conductive layer is spliced with the insulation for long duration. For this reason we recommend a peeling tool for installation.

Note

- rm = round conductor, multi-wire
- Further types and dimensions on request.
- AWG sizes are approximate equivalent values. The actual cross-section is in mm².

Application

Suitable for indoor installation and in cable ducts, outdoors, underground and in water as well as for installation on cable trays for industries, switch-boards and power stations. The PE-outer sheath is resistant to high mechanical stress for laying the cables. This PE sheath is not flame retardant acc. to DIN EN 60332-1-2. The inner conducting layer between the conductor and the XLPE insulation and the firmly bonded outer conducting layer on the XLPE insulation assures a construction free of partial discharges with high operational reliability.

Part no.	No.cores x cross-sec. mm ²	Operation voltage max.	Nominal voltage kV	Insulation thickness mm	Screen cross-sec. mm ²	Outer Ø app. mm	Cop. weight kg / km	Alu weight kg / km	Weight app. kg / km	AWG-No.
32600	1 x 35 rm / 16	12	6 / 10	3,4	16	26,0	182,0	102,0	780,0	2
32601	1 x 50 rm / 16	12	6 / 10	3,4	16	28,0	182,0	145,0	850,0	1
32602	1 x 70 rm / 16	12	6 / 10	3,4	16	30,0	182,0	203,0	980,0	2/0
32603	1 x 95 rm / 16	12	6 / 10	3,4	16	31,0	182,0	276,0	1080,0	3/0
32604	1 x 120 rm / 16	12	6 / 10	3,4	16	32,0	182,0	348,0	1150,0	4/0
32605	1 x 150 rm / 25	12	6 / 10	3,4	25	34,0	283,0	435,0	1280,0	300 kcmil
32606	1 x 185 rm / 25	12	6 / 10	3,4	25	36,0	283,0	537,0	1420,0	350 kcmil
32607	1 x 240 rm / 25	12	6 / 10	3,4	25	38,0	283,0	696,0	1630,0	500 kcmil
32608	1 x 300 rm / 25	12	6 / 10	3,4	25	40,0	283,0	870,0	1950,0	600 kcmil
32609	1 x 400 rm / 35	12	6 / 10	3,4	35	44,0	394,0	1160,0	2350,0	750 kcmil
32610	1 x 500 rm / 35	12	6 / 10	3,4	35	47,0	394,0	1450,0	2780,0	1000 kcmil
32611	1 x 50 rm / 16	24	12 / 20	5,5	16	33,0	182,0	145,0	920,0	1
32612	1 x 70 rm / 16	24	12 / 20	5,5	16	34,0	182,0	203,0	1030,0	2/0
32613	1 x 95 rm / 16	24	12 / 20	5,5	16	36,0	182,0	276,0	1140,0	3/0
32614	1 x 120 rm / 16	24	12 / 20	5,5	16	37,0	182,0	348,0	1250,0	4/0
32615	1 x 150 rm / 25	24	12 / 20	5,5	25	39,0	283,0	435,0	1320,0	300 kcmil
32616	1 x 185 rm / 25	24	12 / 20	5,5	25	41,0	283,0	537,0	1570,0	350 kcmil
32617	1 x 240 rm / 25	24	12 / 20	5,5	25	43,0	283,0	696,0	1780,0	500 kcmil
32618	1 x 300 rm / 25	24	12 / 20	5,5	25	45,0	283,0	870,0	2100,0	600 kcmil
32619	1 x 400 rm / 35	24	12 / 20	5,5	35	48,0	394,0	1160,0	2480,0	750 kcmil
32620	1 x 500 rm / 35	24	12 / 20	5,5	35	50,0	394,0	1450,0	2900,0	1000 kcmil
33090	1 x 630 rm / 35	24	12 / 20	5,5	35	52,0	394,0	1827,0	3380,0	1250 kcmil
33091	1 x 800 rm / 35	24	12 / 20	5,5	35	57,0	394,0	2320,0	4400,0	1500 kcmil
33097	1 x 1000 rm / 35	24	12 / 20	5,5	35	62,0	394,0	2900,0	4780,0	2000 kcmil

Continuation ▶

NA2XS(F)2Y 6/10kV, 12/20kV, 18/30kV XLPE-insulated, alu-conductor, single core, longitudinally water-tight, screened, PE-sheath



Part no.	No. cores x cross-sec. mm ²	Operation voltage max.	Nominal voltage kV	Insulation thickness mm	Screen cross-sec. mm ²	Outer Ø app. mm	Cop. weight kg / km	Alu weight kg / km	Weight app. kg / km	AWG-No.
32621	1 x 50 rm / 16	36	18 / 30	8	16	37,0	182,0	145,0	1250,0	1
32622	1 x 70 rm / 16	36	18 / 30	8	16	38,0	182,0	203,0	1500,0	2/0
32623	1 x 95 rm / 16	36	18 / 30	8	16	40,0	182,0	276,0	1700,0	3/0
32624	1 x 120 rm / 16	36	18 / 30	8	16	42,0	182,0	348,0	1800,0	4/0
32625	1 x 150 rm / 25	36	18 / 30	8	25	43,0	283,0	435,0	2050,0	300 kcmil
32626	1 x 185 rm / 25	36	18 / 30	8	25	45,0	283,0	537,0	2150,0	350 kcmil
32627	1 x 240 rm / 25	36	18 / 30	8	25	47,0	283,0	696,0	2400,0	500 kcmil
32628	1 x 300 rm / 25	36	18 / 30	8	25	50,0	283,0	870,0	2700,0	600 kcmil
32629	1 x 400 rm / 35	36	18 / 30	8	35	53,0	394,0	1160,0	3200,0	750 kcmil
32630	1 x 500 rm / 35	36	18 / 30	8	35	56,0	394,0	1450,0	3555,0	1000 kcmil
31219	1 x 630 rm / 35	36	18 / 30	8	35	58,0	394,0	1827,0	3790,0	1250 kcmil

Dimensions and specifications may be changed without prior notice. (RQ03)

NA2XS(FL)2Y 6/10kV, 12/20kV, 18/30kV XLPE-insulated, alu-conductor, single core, longitudinally and crosswise water-tight, screened, PE-sheath



Technical data

- XLPE-insulated power cables to DIN VDE 0276 part 620, HD 620 S2 and IEC 60502
- **Temperature range** during installation up to -20°C
- **Operating temperature** max. + 90°C
- **Short circuit temperature** 250°C (short circuit duration max. 5 s)
- **Nominal voltages** U₀/U 6/10 kV, 12/20 kV, 18/30 kV
- **Operating voltages** for 6/10 kV = max. 12 kV for 12/20 kV = max. 24 kV for 18/30 kV = max. 36 kV
- **Test voltages** for 6/10 kV = 15 kV for 12/20 kV = 30 kV for 18/30 kV = 45 kV
- **Minimum bending radius** 15x cable Ø
- **Power ratings** see Technical Informations

Cable structure

- Aluminium-conductor, to DIN VDE 0295 cl.2, multi-wire, BS 6360 cl.2, IEC 60228 cl.2
- Inner semi-conducting coating
- Core insulation of cross-linked polyethylene (XLPE), compound type DIX8 to HD 620 S2
- Outer extrusion of semi-conducting coating spliced with the XLPE-insulation
- Longitudinally water-tight, conductive wrapping
- Screen: Braiding of copper wires with one or two tapes applied helically
- Longitudinally water-tight wrapping
- Aluminium tape spliced with PE sheath
- Outer sheath of PE compound type DMP2 to HD 620 S2
- Sheath colour black
- Sheath wall thickness nominal value 2,5 mm

Properties

- The materials used in manufacture are cadmium-free and contain no silicone and free from substances harmful to the wetting properties of lacquers
- **Installation notes** To guarantee an optimum on operating reliability the extruded semi-conductive layer is spliced with the insulation for long duration. For this reason we recommend a peeling tool for installation.

Note

- rm = round conductor, multi-wire
- Further types and dimensions on request.
- AWG sizes are approximate equivalent values. The actual cross-section is in mm².

Application

Installation primarily for power utility grids and in cable ducts, outdoors, underground and in water, and also on pallets for manufacturing plants, switchgear and power stations. The resistant Al/PE-laminated sheathing acts as a cross water barrier. It inhibits the diffusion of water. In case of sheathing damage, water impact is contained at the flaw. The cable can be severely mechanically stressed during installation and operation. The PE sheathing is not flame-retardant to DIN EN 60332-1-2. The internal conductive layer between conductor and VPE insulation and the adherent external conductive layer on the VPE insulation guarantees a design with high operational safety and no partial discharge.

Part no.	No. cores x cross-sec. mm ²	Operation voltage max.	Nominal voltage kV	Insulation thickness mm	Screen cross-sec. mm ²	Outer Ø app. mm	Cop. weight kg / km	Alu weight kg / km	Weight app. kg / km	AWG-No.
38062	1 x 50 rm / 16	12	6 / 10	3,4	16	30,0	182,0	145,0	710,0	1
38063	1 x 70 rm / 16	12	6 / 10	3,4	16	32,0	182,0	203,0	890,0	2/0
38064	1 x 95 rm / 16	12	6 / 10	3,4	16	33,0	182,0	276,0	1100,0	3/0
38065	1 x 120 rm / 16	12	6 / 10	3,4	16	34,0	182,0	348,0	1330,0	4/0
38066	1 x 150 rm / 25	12	6 / 10	3,4	25	36,0	283,0	435,0	1450,0	300 kcmil
38067	1 x 185 rm / 25	12	6 / 10	3,4	25	38,0	283,0	537,0	1580,0	350 kcmil
38068	1 x 240 rm / 25	12	6 / 10	3,4	25	40,0	283,0	696,0	1780,0	500 kcmil
38069	1 x 300 rm / 25	12	6 / 10	3,4	25	42,0	283,0	870,0	1990,0	600 kcmil
38070	1 x 400 rm / 35	12	6 / 10	3,4	35	46,0	394,0	1160,0	2320,0	750 kcmil
38071	1 x 500 rm / 35	12	6 / 10	3,4	35	49,0	394,0	1450,0	2690,0	1000 kcmil
38072	1 x 630 rm / 35	12	6 / 10	3,4	35	51,0	394,0	1827,0	3160,0	1250 kcmil
38073	1 x 50 rm / 16	24	12 / 20	5,5	16	35,0	182,0	145,0	870,0	1
38074	1 x 70 rm / 16	12	12 / 20	5,5	16	36,0	182,0	203,0	1060,0	2/0
38075	1 x 95 rm / 16	24	12 / 20	5,5	16	38,0	182,0	276,0	1280,0	3/0
38076	1 x 120 rm / 16	24	12 / 20	5,5	16	39,0	182,0	348,0	1520,0	4/0
33089	1 x 150 rm / 25	24	12 / 20	5,5	25	41,0	283,0	435,0	1650,0	300 kcmil
38077	1 x 185 rm / 25	24	12 / 20	5,5	25	43,0	283,0	537,0	1800,0	350 kcmil
38078	1 x 240 rm / 25	24	12 / 20	5,5	25	45,0	283,0	696,0	2000,0	500 kcmil
38079	1 x 300 rm / 25	24	12 / 20	5,5	25	47,0	283,0	870,0	2230,0	600 kcmil
38080	1 x 400 rm / 35	24	12 / 20	5,5	35	50,0	394,0	1160,0	2580,0	750 kcmil
38081	1 x 500 rm / 35	24	12 / 20	5,5	35	54,0	394,0	1450,0	2980,0	1000 kcmil
38082	1 x 630 rm / 35	24	6 / 10	5,5	35	55,0	394,0	1827,0	3480,0	1250 kcmil

Continuation ▶

NA2XS(FL)2Y 6/10kV, 12/20kV, 18/30kV XLPE-insulated, alu-conductor, single core, longitudinally and crosswise water-tight, screened, PE-sheath



Part no.	No. cores x cross-sec. mm ²	Operation voltage max.	Nominal voltage kV	Insulation thickness mm	Screen cross-sec. mm ²	Outer Ø app. mm	Cop. weight kg / km	Alu weight kg / km	Weight app. kg / km	AWG-No.
33084	1 x 50 rm / 16	36	18 / 30	8	16	39,0	182,0	145,0	1100,0	1
33085	1 x 70 rm / 16	36	18 / 30	8	16	40,0	182,0	203,0	1300,0	2/0
38083	1 x 95 rm / 16	36	18 / 30	8	16	42,0	182,0	276,0	1530,0	3/0
38084	1 x 120 rm / 16	36	18 / 30	8	16	44,0	182,0	348,0	1780,0	4/0
38085	1 x 150 rm / 25	36	18 / 30	8	25	45,0	283,0	435,0	1920,0	300 kcmil
38086	1 x 185 rm / 25	36	18 / 30	8	25	47,0	283,0	537,0	2080,0	350 kcmil
38087	1 x 240 rm / 25	36	10 / 30	8	25	49,0	283,0	696,0	2300,0	500 kcmil
38088	1 x 300 rm / 25	36	18 / 30	8	25	52,0	283,0	870,0	2550,0	600 kcmil
38089	1 x 400 rm / 35	36	18 / 30	8	35	55,0	394,0	1160,0	2960,0	750 kcmil
38090	1 x 500 rm / 35	36	18 / 30	8	35	30,0	394,0	1450,0	3380,0	1000 kcmil
38091	1 x 630 rm / 35	36	18 / 30	8	35	60,0	394,0	1827,0	3900,0	1250 kcmil

Dimensions and specifications may be changed without prior notice. (RQ03)



HELUWIND® WK POWERLINE ALU: ALUMINIUM
CABLES WITH FLEXIBLE, FINE WIRE CONSTRUCTION



HELUWIND® WK POWERLINE ALU 105°C

0,6/1kV, flexible aluminium conductor



Technical Data

- **Temperature range**
fixed installation: -40°C up to +105°C
flexing: -20°C up to +105°C
- **Operating temperature at conductor**
max. +105°C
- **Nominal voltage**
0,6/1 kV (50Hz)
- **Test voltage**
2,5 kV (50Hz)
- **Minimum bending radius**
flexing: 10 x cable diameter
fixed installation: 4 x cable diameter
- **Flame test**
IEC 60332-1
- **Approvals**
acc. to DIN VDE 0250-813
UL/CSA in preparation

Cable Structure

- Aluminium conductor, finely stranded wires
- Special insulation, black
- Special compound sheath
- Black sheath

Properties

- Abrasion resistant
- UV resistant
- Oil resistant
- Easy to assemble
- Recyclable

Note

Please ask for our extended notes/information on the properties and for the necessary connection technology.

Application

The HELUWIND® WK POWERLINE ALU is a highly flexible, aluminium cable with a finely stranded structure and is designed for use in the power engineering sector, specifically for power cabling in industrial applications. Thanks to its high level of flexibility and reduced weight, this cable is an interesting option compared to fine-stranded copper cables in many applications.

The HELUWIND® WK POWERLINE ALU series unlocks its full potential, when it comes to power wiring of wind power plants. Due to its low weight, cables can be fed through the tower in one length. This eliminates the need for the time-consuming cabling of individual tower segments. However, the key benefit is an increased reliability of the connection technology: The number of interruptions between the topmost tower segment and the converter can be reduced from 90 connection points to just 18 (depending on the number of power cables and tower segments). As a result, the amount of time required for installation can drop from several days, to a few hours. For torsion applications, we recommend the HELUWIND® WK 103-T, WK 135-T or WK 137-T.

The HELUWIND® WK POWERLINE ALU may only be used with certified connection technology from HELUKABEL®. This includes C8 crimp connections and screwed connections; both described in the "Connection Technology" section and tested in accordance with IEC 61238-1 cl. A.

The cable is also available in a halogen-free design, with UL/CSA approval, and a rated voltage of 1.8/3 kV. The "robust" version features a high abrasion and mechanical load resistant PUR sheath.

CE = The product conforms with the EC Low-Voltage Directive 2006/95/EC.

Part no.	No. cores x cross-sec. mm ²	AWG no.	Outer-Ø approx. mm	AL weight approx. kg/km	Weight approx. kg/km	Price EUR/100m AL 0,-
707062	1 x 70	2/0	17,4	206,0	379,0	on request
707063	1 x 95	3/0	18,8	280,0	480,0	on request
707064	1 x 120	4/0	20,6	355,0	576,0	on request
706408	1 x 150	300 kcmil	22,4	441,0	665,0	on request
706088	1 x 185	350 kcmil	24,5	544,0	950,0	on request
706089	1 x 240	500 kcmil	27,5	706,0	1150,0	on request
706084	1 x 300	600 kcmil	31,9	882,0	1400,0	on request
706085	1 x 400	750 kcmil	36,7	1176,0	1680,0	on request

Dimensions and specifications may be changed without prior notice.

HELUWIND® WK POWERLINE ALU robust 105°C

0,6/1kV, flexible aluminium conductor



Technical Data

- **Temperature range**
fixed installation: -40°C up to +105°C
flexing: -20°C up to +105°C
- **Operating temperature at conductor**
max. +105°C
- **Nominal voltage**
0,6/1 kV (50Hz)
- **Test voltage**
2,5 kV (50Hz)
- **Minimum bending radius**
flexing: 10 x cable diameter
fixed installation: 4 x cable diameter
- **Flame test**
IEC 60332-1
- **Approvals**
acc. to DIN VDE 0250-813
UL/CSA in preparation

Cable Structure

- Aluminium conductor, finely stranded wires
- Special insulation, black
- Special compound sheath
- Black sheath

Properties

- Extremely abrasion resistant
- UV resistant
- Oil resistant
- Easy to assemble
- Recyclable

Note

Please ask for our extended notes/information on the properties and for the necessary connection technology. .

Application

The HELUWIND® WK POWERLINE ALU is a highly flexible, aluminium cable with a finely stranded structure and is designed for use in the power engineering sector, specifically for power cabling in industrial applications. Thanks to its high level of flexibility and reduced weight, this cable is an interesting option compared to fine-stranded copper cables in many applications.

The HELUWIND® WK POWERLINE ALU series unlocks its full potential, when it comes to power wiring of wind power plants. Due to its low weight, cables can be fed through the tower in one length. This eliminates the need for the time-consuming cabling of individual tower segments. However, the key benefit is an increased reliability of the connection technology: The number of interruptions between the topmost tower segment and the converter can be reduced from 90 connection points to just 18 (depending on the number of power cables and tower segments). As a result, the amount of time required for installation can drop from several days, to a few hours. For torsion applications, we recommend the HELUWIND® WK 103-T, WK 135-T or WK 137-T.

The HELUWIND® WK POWERLINE ALU may only be used with certified connection technology from HELUKABEL®. This includes C8 crimp connections and screwed connections; both described in the "Connection Technology" section and tested in accordance with IEC 61238-1 cl. A.

The cable is also available in a halogen-free design, with UL/CSA approval, and a rated voltage of 1.8/3 kV. The "robust" version features a high abrasion and mechanical load resistant PUR sheath.

CE = The product conforms with the EC Low-Voltage Directive 2006/95/EC.

Part no.	No. cores x cross-sec. mm ²	AWG no.	Outer-Ø approx. mm	AL weight approx. kg/km	Weight approx. kg/km	Price EUR/100m AL 0,-
707097	1 x 70	2/0	17,4	206	460	on request
707098	1 x 95	3/0	18,8	280	536	on request
707099	1 x 120	4/0	20,6	355	576	on request
707100	1 x 150	300 kcmil	22,4	441	665	on request
707101	1 x 185	350 kcmil	24,5	544	950	on request
707102	1 x 240	500 kcmil	27,5	706	1150	on request
707103	1 x 300	600 kcmil	31,9	882	1398	on request
707104	1 x 400	750 kcmil	36,7	1176	1588	on request

Dimensions and specifications may be changed without prior notice.

HELUWIND® WK POWERLINE ALU 105°C

1,8/3kV, flexible aluminium conductor, direct burial



Technical Data

- **Temperature range**
fixed installation: -40°C up to +105°C
flexing: -20°C up to +105°C
- **Operating temperature at conductor**
max. +105°C
- **Nominal voltage**
1,8/3 kV (50Hz)
- **Test voltage**
9 kV (50Hz)
- **Minimum bending radius**
flexing: 10 x cable diameter
fixed installation: 4 x cable diameter
- **Flame test**
IEC 60332-1
- **Approvals**
acc. to DIN VDE 0250-813
UL/CSA in preparation

Cable Structure

- Aluminium conductor, finely stranded wires
- Special insulation, black
- Special compound sheath
- Black sheath

Properties

- Abrasion resistant
- UV resistant
- Oil resistant
- Easy to assemble
- Recyclable

Note

Please ask for our extended notes/information on the properties and for the necessary connection technology.

Application

The HELUWIND® WK POWERLINE ALU is a highly flexible, aluminium cable with a finely stranded structure and is designed for use in the power engineering sector, specifically for power cabling in industrial applications. Thanks to its high level of flexibility and reduced weight, this cable is an interesting option compared to fine-stranded copper cables in many applications.

The HELUWIND® WK POWERLINE ALU series unlocks its full potential, when it comes to power wiring of wind power plants. Due to its low weight, cables can be fed through the tower in one length. This eliminates the need for the time-consuming cabling of individual tower segments. However, the key benefit is an increased reliability of the connection technology: The number of interruptions between the topmost tower segment and the converter can be reduced from 90 connection points to just 18 (depending on the number of power cables and tower segments). As a result, the amount of time required for installation can drop from several days, to a few hours. For torsion applications, we recommend the HELUWIND® WK 103-T, WK 135-T or WK 137-T.

The HELUWIND® WK POWERLINE ALU may only be used with certified connection technology from HELUKABEL®. This includes C8 crimp connections and screwed connections; both described in the "Connection Technology" section and tested in accordance with IEC 61238-1 cl. A.

The cable is also available in a halogen-free design, with UL/CSA approval, and a rated voltage of 0.6/1 kV. The "robust" version features a high abrasion and mechanical load resistant PUR sheath.

CE = The product conforms with the EC Low-Voltage Directive 2006/95/EC.

Part no.	No. cores x cross-sec. mm²	AWG no.	Outer-Ø approx. mm	AL weight approx. kg/km	Weight approx. kg/km	Price EUR/100m AL 0,-
707647	1 x 185	350 kcmil	26	544	1020	on request
706578	1 x 240	500 kcmil	28,4	706	1250	on request
707432	1 x 300	600 kcmil	33,2	882	1520	on request
707648	1 x 400	750 kcmil	38,1	1176	1855	on request

Dimensions and specifications may be changed without prior notice.

HELWIND® WK POWERLINE ALU robust 105°C

1,8/3kV, flexible aluminium conductor



Technical Data

- **Temperature range**
fixed installation: -40°C up to +105°C
flexing: -20°C up to +105°C
- **Operating temperature at conductor**
max. +105°C
- **Nominal voltage**
1,8/3 kV (50Hz)
- **Test voltage**
9 kV (50Hz)
- **Minimum bending radius**
flexing: 10 x cable diameter
fixed installation: 4 x cable diameter
- **Flame test**
IEC 60332-1
- **Approvals**
acc. to DIN VDE 0250-813
UL/CSA in preparation

Cable structure

- Aluminium conductor, finely stranded wires
- Special insulation, black
- Special compound sheath
- Black sheath

Properties

- Extremely abrasion resistant
- UV resistant
- Oil resistant
- Easy to assemble
- Recyclable

Note

Please ask for our extended notes/information on the properties and for the necessary connection technology.

Application

The HELWIND® WK POWERLINE ALU is a highly flexible, aluminium cable with a finely stranded structure and is designed for use in the power engineering sector, specifically for power cabling in industrial applications. Thanks to its high level of flexibility and reduced weight, this cable is an interesting option compared to fine-stranded copper cables in many applications.

The HELWIND® WK POWERLINE ALU series unlocks its full potential, when it comes to power wiring of wind power plants. Due to its low weight, cables can be fed through the tower in one length. This eliminates the need for the time-consuming cabling of individual tower segments. However, the key benefit is an increased reliability of the connection technology: The number of interruptions between the topmost tower segment and the converter can be reduced from 90 connection points to just 18 (depending on the number of power cables and tower segments). As a result, the amount of time required for installation can drop from several days, to a few hours. For torsion applications, we recommend the HELWIND® WK 103-T, WK 135-T or WK 137-T.

The HELWIND® WK POWERLINE ALU may only be used with certified connection technology from HELUKABEL®. This includes C8 crimp connections and screwed connections; both described in the "Connection Technology" section and tested in accordance with IEC 61238-1 Cl. A.

The cable is also available in a halogen-free design, with UL/CSA approval, and a rated voltage of 0.6/1 kV. The "robust" version features a high abrasion and mechanical load resistant PUR sheath.

☑ = The product conforms with the EC Low-Voltage Directive 2006/95/EC.

Part no.	No. cores x cross-sec. mm ²	AWG no.	Outer-Ø approx. mm	AL weight approx. kg/km	Weight approx. kg/km	Price EUR/100m AL 0,-
707692	1 x 185	350 kcmil	26	544	1020	on request
707693	1 x 240	500 kcmil	28,4	706	1250	on request
707694	1 x 300	600 kcmil	33,2	882	1520	on request
707695	1 x 400	750 kcmil	38,1	1176	1855	on request

Dimensions and specifications may be changed without prior notice.

HELWIND® WK POWERLINE ALU halogen free 105°C

1,8/3kV, flexible aluminium conductor



Technical Data

- **Temperature range**
fixed installation: -40°C up to +105°C
flexing: -20°C up to +105°C
- **Operating temperature at conductor**
max. +105°C
- **Nominal voltage**
1,8/3 kV (50Hz)
- **Test voltage**
9 kV (50Hz)
- **Minimum bending radius**
flexing: 10 x cable diameter
fixed installation: 4 x cable diameter
- **Flame test**
IEC 60332-1
- **Approvals**
acc. to DIN VDE 0250-813
UL/CSA in preparation

Cable structure

- Aluminium conductor, finely stranded wires
- Special insulation black
- Special compound sheath
- Black sheath

Properties

- Halogen-free
- Abrasion resistant
- UV resistant
- Oil resistant
- Easy to assemble
- Recyclable

Note

Please ask for our extended notes/information on the properties and for the necessary connection technology.

Application

The HELWIND® WK POWERLINE ALU is a highly flexible, aluminium cable with a finely stranded structure and is designed for use in the power engineering sector, specifically for power cabling in industrial applications. Thanks to its high level of flexibility and reduced weight, this cable is an interesting option compared to fine-stranded copper cables in many applications.

The HELWIND® WK POWERLINE ALU series unlocks its full potential, when it comes to power wiring of wind power plants. Due to its low weight, cables can be fed through the tower in one length. This eliminates the need for the time-consuming cabling of individual tower segments. However, the key benefit is an increased reliability of the connection technology: The number of interruptions between the topmost tower segment and the converter can be reduced from 90 connection points to just 18 (depending on the number of power cables and tower segments). As a result, the amount of time required for installation can drop from several days, to a few hours. For torsion applications, we recommend the HELWIND® WK 103-T, WK 135-T or WK 137-T.

The HELWIND® WK POWERLINE ALU may only be used with certified connection technology from HELUKABEL®. This includes C8 crimp connections and screwed connections; both described in the "Connection Technology" section and tested in accordance with IEC 61238-1 cl. A.

The cable is also available with UL/CSA approval.

☞ = The product conforms with the EC Low-Voltage Directive 2006/95/EC.

Part no.	No. cores x cross-sec. mm ²	AWG no.	Outer-Ø approx. mm	AL weight approx. kg/km	Weight approx. kg/km	Price EUR/100m AL 0,-
709143	1 x 185	350 kcmil	26,0	544,0	1020,0	on request
709144	1 x 240	500 kcmil	28,4	706,0	1150,0	on request
709145	1 x 300	600 kcmil	33,2	882,0	1400,0	on request
709146	1 x 400	750 kcmil	38,1	1176,0	1680,0	on request

Dimensions and specifications may be changed without prior notice.

HELWIND® WK POWERLINE ALU MS SINGLE

3,6/6kV, 12/20kV, 18/30kV, finely stranded aluminium conductor



Technical Data

- **Temperature range**
flexing: -20°C up to +90°C
- **Nominal voltage**
3,6/6kV, 12/20kV, 18/30kV
- **Maximum short circuit conductor temperature**
+250°C
- **Minimum bending radius**
flexing: 10 x cable diameter
fixed installation: 8 x cable diameter

Cable structure

- **Conductor:**
Highly flexible aluminium conductor
Extruded inner semi conductive layer
- **Insulation:**
Material: EPR
1st semi conductive layer: extruded
2nd semi conductive layer: tape wrapped
Screen: wrapped copper wires
- **Outer sheath:**
Colour: red
Material: special rubber compound

Properties

- Oil resistant
- UV resistant
- Hydrolysis resistant
- Ozone resistant
- Flame retardant
- Heat resistant

Note

Please ask for our extended notes/information on the properties and for the necessary connection technology.

Application

Designed for use in switchboards and power generators, where very small bending radii are required. In wind turbines, for applications requiring flexible connections; ideal to be fed through the tower in one continuous length. This eliminates cost intensive connection points between the individual tower sections.

Not suitable for applications in the cable loop.

3,6/6 (7,2) kV

Part no.	No. cores x cross-sec. mm ²	AWG no.	Outer Ø approx. mm	Weight approx. kg/km	Price
712184	50	1	25,0	807	on request
712185	70	2/0	27,0	932	on request
712186	95	3/0	28,4	1039	on request
712187	120	4/0	30,8	1231	on request
712188	150	300 kcmil	33,4	1492	on request
712189	185	350 kcmil	34,0	1633	on request
712190	240	500 kcmil	38,1	1610	on request
712191	300	600 kcmil	41,7	2293	on request
712192	400	750 kcmil	46,3	2791	on request

18/30 (36) kV

Part no.	No. cores x cross-sec. mm ²	AWG no.	Outer Ø approx. mm	Weight approx. kg/km	Price
712202	50	1	36,6	1648	on request
712203	70	2/0	38,8	1853	on request
712204	95	3/0	40,2	1997	on request
712205	120	4/0	42,6	2285	on request
712206	150	300 kcmil	45,2	2586	on request
712207	185	350 kcmil	45,8	2771	on request
712208	240	500 kcmil	49,7	3139	on request
712209	300	600 kcmil	52,7	3529	on request
712210	400	750 kcmil	57,1	4123	on request

12/20 (24) kV

Part no.	No. cores x cross-sec. mm ²	AWG no.	Outer Ø approx. mm	Weight approx. kg/km	Price
712193	50	1	31,2	1214	on request
712194	70	2/0	33,4	1389	on request
712195	95	3/0	34,8	1516	on request
712196	120	4/0	37,2	1756	on request
712197	150	300 kcmil	39,8	2043	on request
712198	185	350 kcmil	40,4	2208	on request
712199	240	500 kcmil	44,3	2535	on request
712200	300	600 kcmil	47,3	2884	on request
712201	400	750 kcmil	51,7	3421	on request

Dimensions and specifications may be changed without prior notice.

HELWIND® WK POWERLINE ALU MULTICORE

0,6/1kV, finely stranded aluminium conductor



Technical Data

• Temperature range

fixed installation: -40°C up to +90°C
flexing: -20°C up to +90°C

• Nominal voltage

0,6/1kV

• Minimum bending radius

flexing: 8 x cable diameter
fixed installation: 6 x cable diameter

• Flame retardant

EN 60332-1 Low Smoke Emission

Cable structure

- Aluminium conductor, finely stranded
- Special PVC insulation
- Other colours on request
- Core identification colour code
- Special PVC compound sheath
- On request: rubber insulated outer sheath
- Black sheath

Properties

- Oil resistant
- UV resistant
- Flexible
- Lightweight
- Robust
- Durable
- Easy to assemble

Note

Please ask for our extended notes/information on the properties and for the necessary connection technology.

Application

The HELWIND® WK POWERLINE ALU MULTICORE is a highly flexible aluminium cable with a fine wire stranded structure. Thanks to its high level of flexibility and reduced weight, this cable is suitable for many industrial applications.

The HELWIND® WK POWERLINE ALU MULTICORE may only be used with certified connection technology from HELUKABEL®. This includes C8 crimp connections and screwed connections; both described in the "Connection Technology" section and tested in accordance with IEC 61238-1 cl. A.

The cable is also available in other insulation materials and in a halogen-free design.

CE = The product conforms with the EC Low-Voltage Directive 2006/95/EC.

Part no.	No. cores x cross-sec. mm ²	AWG no.	Outer-Ø approx. mm	AL weight approx. kg/km	Weight approx. kg/km	Price EUR/100m AL 0,-
711083	4 x 50	1	38,8	590	980	on request
711084	4 x 70	2/0	43,0	824	1280	on request
711085	4 x 95	3/0	50,0	1120	1640	on request
711086	4 x 120	4/0	54,5	1420	2005	on request
711087	4 x 150	300 kcmil	58,0	1764	2320	on request

Dimensions and specifications may be changed without prior notice.

HELWIND® WK POWERLINE ALU SINGLE

0,6/1 kV, flexible aluminium stranded wires



Technical Data

- **Temperature range**
fixed installation: -40°C to +105°C,
flexing: -20°C to +90°C
- **Operating temperature at conductor**
max. +105°C
- **Nominal voltage**
0.6/1kV (50Hz)
- **Test voltage**
2.5kV (50Hz)
- **Minimum bending radius**
4 x cable diameter according to
DIN VDE 0298 Part 3, Table 2
- **Non-flammability**
IEC 60332-1
- **Approval**
conforms to DIN VDE 0250-813
UL/CSA in preparation

Cable Structure

- Fine-wire aluminium strands
- Special insulation, black
- Other colours available upon request

Properties

- UV resistant
- Oil resistant
- Easy to assemble
- Recyclable

Note

Please ask for our extended notes/information on the properties and for the necessary connection technology.

Application

The HELWIND® WK POWERLINE ALU Single is a highly flexible, fine-wire, single conductor with a 105°C heat-resistant wire insulation. Its reduced weight of up to 50% over comparable copper wires (H07-VK) provides a huge advantage in many applications.

The HELWIND® WK POWERLINE ALU Single may only be used with certified connection technology from HELUKABEL®. This includes C8 crimp connections and screwed connections; both described in the "Connection Technology" section and tested in accordance with IEC 61238-1 cl. A. A space-saving welding technique is available as an additional option.

The wire is also available in a halogen-free design, with UL/CSA approval, and a rated voltage of 1.8/3 kV. Suitable for the interior wiring of devices, distributors, and switchboards as well as for protected laying in and on lamps with a nominal voltage up to 1000V AC or up to 750V DC towards the end. Not suitable for direct laying on trays, gutters, or tubs.

CE = The product conforms with the EC Low-Voltage Directive 2006/95/EC.

Part no.	No. cores x cross-sec. mm ²	AWG No.	Outer Ø approx. mm	AL Weight approx. kg/km	Weight approx. kg/km	Price EUR/100m AL 0,-
709914	1 x 70	2/0	15,9	206,0	315,0	on request
709915	1 x 95	3/0	17,2	280,0	420,0	on request
709916	1 x 120	4/0	18,2	355,0	507,0	on request
709917	1 x 150	300 kcmil	19,2	441,0	601,0	on request

Part no.	No. cores x cross-sec. mm ²	AWG No.	Outer Ø approx. mm	AL Weight approx. kg/km	Weight approx. kg/km	Price EUR/100m AL 0,-
709918	1 x 185	350 kcmil	22,1	544,0	950,0	on request
709919	1 x 240	500 kcmil	25,1	706,0	1060,0	on request
709920	1 x 300	600 kcmil	27,8	882,0	1290,0	on request
709921	1 x 400	750 kcmil	32,7	1176,0	1460,0	on request

Dimensions and specifications may be changed without prior notice.



ALUMINIUM CABLE RM UL/CSA APPROVED

MV105 ALU shielded 25KV



HELWIND® WK RHH/RHW-2 ALU

UL listed as types RHW/RHW-2. RW90/R90, FT4 per CSA



Technical Data

- **Temperature range**
flexing -40°C up to +90°C (wet & dry)
- **Nominal voltage**
2000 V
- **Approvals**
UL 44 for Thermoset-Insulated Wires and Cables
ICEA S-95 -658 / NEMA WC70 for Non-shielded 0-2 kV Cables
All cross sections are rated VW1 (fire protection classification)

Cable structure

- **Conductor:**
Aluminium AA-8000 alloy compacted conductor, Class B stranding, per ASTM B801
Sizes: 6 AWG - 1000 kcmil
- **Insulation:**
Flame retardant thermoset ethylene propylene rubber (EPR) compound
- **Sheath:**
Black flame retardant thermoset chlorinated polyethylene (CPE) compound

Properties

- Sheath is rated Oil Resistance I or II per UL 44
- Rated Sun Resistance for CT use, 1/0 AWG and larger
- Other cross sections on request
- **RHH/RHW-2 600 V on request**

Application

For power, lighting, signal and control circuits installed in wet or dry locations. In conduit, duct, tray, and open air, and aerial installations. Suitable for use in industrial areas, fixed installation in wind turbines and utility systems where flame resistance is essential.

2000 V

Part no.	Cross-section AWG/kcmil	Approximate Outside Diameter-Ø inch	Approximate Net Weight lb/kft	Price
708746	6	0,35	71	on request
708747	4	0,39	91	on request
708748	2	0,45	124	on request
708749	1	0,54	174	on request
708750	1/0	0,57	202	on request
708751	2/0	0,61	238	on request
708752	3/0	0,66	281	on request
708753	4/0	0,71	335	on request
708754	250	0,82	429	on request
712222	300	0,87	491	on request
712223	350	0,92	552	on request
712224	400	0,96	612	on request
712225	500	1,04	729	on request
712226	600	1,15	878	on request
712227	750	1,24	1052	on request
712228	1000	1,39	1338	on request

Dimensions and specifications may be changed without prior notice.

MV-90 / MV-105 ALUMINIUM UL listed



Technical Data

- UL 1072
Medium-Voltage Power Cables
MV-90/MV-105 shielded:
5 kV – 46 kV
MV-90 non-shielded:
2.4 kV
- **Temperature range**
during installation up to -5 °C
- **Conductor operation temperatures**
Normal:
MV-90: 90 °C (194 °F)
MV-105: 105 °C (221 °F)
Emergency: 130 °C (266 °F)
Short circuit: 250 °C (482 °F)
- **Maximum operating voltage**
MV-90/MV-105 shielded:
5 kV /8kV/15kV/25kV/ 35 kV 100%
and 133% IL
MV-90 non-shielded :
2.4 kV per UL
5 kV, 100% and 3.0 kV, 133% per ICEA
- **Minimum bending radius**
MV-90 2,4 KV non-shielded =
8 x OD
MV-90 and 105 copper wire shielded =
8 x OD
MV-90 and 105 copper tape shielded =
12 x OD

Cable structure

- **Conductor:**
Soft annealed uncoated copper compacted Class B per ASTM B496 or hard drawn Aluminium-1350 compacted Class B per ASTM B400.
Sizes: 8 AWG (6 AWG Aluminium) up to 1000 kcmil (on request, larger conductor sizes available)
Optional : annealed AA-8000 Aluminium compacted Class B per ASTM B80.
- **Conductor Shield:**
Semi-conducting cross-linked polyethylene (XLPE).
- **Insulation:**
MV-90: Thermoset cross-linked polyethylene (XLPE).
MV-105: Thermoset ethylene propylene rubber (EPR).
- **Insulation Shield:**
MV-90/MV-105 shielded
Semi conducting cross-linked polyethylene (XLPE).
- **Metallic Shield:**
MV-90/MV-105 shielded
Copper wires shield:
Solid soft annealed uncoated copper wires per ASTM B3, helically applied and uniformly spaced.
Copper tape shield:
Soft annealed uncoated copper tape, 5 mil thick, 25% minimum overlap.
- **Jacket:**
Black sunlight resistance and flame retardant polyvinyl chloride (PVC) compound.

Properties

- Rated as Sunlight Resistance for CT use 1/0 AWG and larger
Oil Resistance I jacket
Flame retardend (PVC jacket)
- **MV-90 / MV-105 shielded:**
ICEA S-93-639/NEMA WC74
5 kV – 46 kV Shielded Power Cables
ICEA S-97-682
Standard for Utility Shielded Power Cables
Rated 5 kV – 46 kV
AEIC CS8
Specification for Extruded Dielectric, Shielded Power Cables Rated 5 kV – 46 kV
- **MV-90 non-shielded:**
ICEA S-96-659/NEMA WC71
Standard for non-shielded cables
Rated 2001-5000 volts for use in the Distribution of Electrical Energy

Optional:

- Halogen free
- EPR/CPE as FT4 rated

Application

MV-90/ MV-105 shielded: Primary power and distribution circuits in industrial and commercial installations, power circuits in generating plants where line to ground fault current are within shield capabilities. May be used in wet or dry locations, installed in raceways, duct, and open air, aerially or directly buried as permitted by NEC. MV-90 non-shielded: Per NEC, use is limited to 2400 V. For use in industrial and utility applications, for dry locations, in accordance with NEC.

Aluminium MV-90 non-shielded 2,4 KV

XLPE Insulated
100% Insulation Level

Size AWG or kcmil	Part no. ALU	Part no. copper	Approx. OD inch	ALU Weight approx. lb/kft	Copper Weight approx. lb/kft
8	711136	711660	0,39	–	94
6	711137	711661	0,42	74	131
4	711138	711662	0,47	97	187
2	711139	711663	0,52	131	273
1	711140	711664	0,55	151	331
1/0	711141	711665	0,59	178	405
2/0	711142	711666	0,63	212	498
3/0	711143	711667	0,68	254	614
4/0	711144	711668	0,73	305	760
250	711145	711669	0,81	361	898
350	711146	711670	0,90	474	1227
500	711147	711671	1,02	641	1715
750	711148	711672	1,22	928	2539
1000	711149	711673	1,38	1197	3344

EPR /PVC Insulated
100%/133% Insulation Levels

Part no. ALU	Part no. copper	Approx. OD inch	ALU Weight approx. lb/kft	Copper Weight approx. lb/kft
711150	711674	0,59	–	208
711151	711675	0,63	197	254
711152	711676	0,67	231	321
711153	711677	0,72	279	422
711154	711678	0,76	308	488
711155	711679	0,79	345	572
711156	711680	0,83	389	675
711157	711681	0,91	470	831
711158	711682	0,96	537	991
711159	711683	1,08	660	1198
711160	711684	1,18	806	1559
711161	711685	1,30	1012	2088
711162	711686	1,54	1434	3047
711163	711687	1,96	1760	3910

Dimensions and specifications may be changed without prior notice.

MV-90 / MV-105 ALUMINIUM UL listed

MV-90/MV-105 Aluminium Shielded 5KV, 100% /133% Insulation Levels

MV-90 XLPE /PVC
CU-Tape Shielded

Size AWG or kcmil	Part no. ALU	Part no. copper	Approx. OD inch	ALU Weight approx. lb/kft	Copper Weight approx. lb/kft
8	711164	711688	-	-	-
6	711165	711689	0,59	188	245
4	711166	711690	0,64	221	311
2	711167	711691	0,69	267	410
1	711168	711692	0,72	295	475
1/0	711169	711693	0,76	331	558
2/0	711170	711694	0,80	373	659
3/0	711171	711695	0,89	460	821
4/0	711172	711696	0,94	526	980
250	711173	711697	0,99	586	1124
350	711174	711698	1,09	724	1477
500	711175	711699	1,21	921	1996
750	711176	711700	1,41	1266	2879
1000	711177	711701	1,57	1573	3723

CU Wire Shielded

Part no. ALU	Part no. copper	Approx. OD inch	ALU Weight approx. lb/kft	Copper Weight approx. lb/kft
711178	711702	-	-	-
711179	711703	0,63	172	229
711180	711704	0,68	202	291
711181	711705	0,73	250	392
711182	711706	0,76	275	455
711183	711707	0,80	308	535
711184	711708	0,88	382	668
711185	711709	0,93	433	793
711186	711710	0,98	494	949
711187	711711	1,03	559	1096
711188	711712	1,13	689	1443
711189	711713	1,25	877	1952
711190	711714	1,45	1215	2828
711191	711715	1,61	1510	3660

MV-105 EPR/PVC
CU-Tape Shielded

Size AWG or kcmil	Part no. ALU	Part no. copper	Approx. OD inch	ALU Weight approx. lb/kft	Copper Weight approx. lb/kft
8	711192	711716	-	-	-
6	711193	711717	0,6	204	260
4	711194	711718	0,65	238	328
2	711195	711719	0,70	287	430
1	711196	711720	0,73	316	496
1/0	711197	711721	0,77	354	581
2/0	711198	711722	0,81	398	684
3/0	711199	711723	0,90	488	849
4/0	711200	711724	0,95	556	1011
250	711201	711725	1,01	619	1157
350	711202	711726	1,10	761	1515
500	711203	711727	1,22	964	2039
750	711204	711728	1,43	1318	2931
1000	711205	711729	1,58	1633	3783

CU Wire Shielded

Part no. ALU	Part no. copper	Approx. OD inch	ALU Weight approx. lb/kft	Copper Weight approx. lb/kft
711206	711730	-	-	-
711207	711731	0,65	188	244
711208	711732	0,69	219	309
711209	711733	0,76	280	423
711210	711734	0,79	307	487
711211	711735	0,83	342	568
711212	711736	0,91	419	705
711213	711737	0,96	472	832
711214	711738	1,01	535	990
711215	711739	1,06	602	1140
711216	711740	1,16	737	1490
711217	711741	1,28	930	2005
711218	711742	1,50	1292	2905
711219	711743	1,65	1599	3749

MV-90 XLPE/PVC Shielded 8KV Aluminium

100% Insulation Level

CU-Tape Shielded

Size AWG or kcmil	Part no. ALU	Part no. copper	Approx. OD inch	ALU Weight approx. lb/kft	Copper Weight approx. lb/kft
6	711220	711744	0,65	214	270
4	711221	711745	0,69	248	338
2	711222	711746	0,75	296	438
1	711223	711747	0,78	325	504
1/0	711224	711748	0,81	362	588
2/0	711225	711749	0,89	440	726
3/0	711226	711750	0,94	496	857
4/0	711227	711751	0,99	563	1018
250	711228	711752	1,05	625	1163
300	711229	711753	1,10	697	1341
350	711230	711754	1,14	766	1519
400	711231	711755	1,19	834	1694
500	711232	711756	1,29	991	2066
600	711233	711757	1,37	1129	2419
750	711234	711758	1,47	1318	2931
1000	711235	711759	1,62	1630	3780

CU Wire Shielded

Part no. ALU	Part no. copper	Approx. OD inch	ALU Weight approx. lb/kft	Copper Weight approx. lb/kft
711284	711808	0,68	200	257
711285	711809	0,73	231	321
711286	711810	0,78	279	422
711287	711811	0,81	305	485
711288	711812	0,89	374	601
711289	711813	0,93	416	703
711290	711814	0,98	469	829
711291	711815	1,03	532	986
711292	711816	1,08	598	1136
711293	711817	1,13	666	1310
711294	711818	1,18	732	1485
711295	711819	1,22	797	1657
711296	711820	1,32	946	2021
711297	711821	1,41	1085	2376
711298	711822	1,50	1267	2880
711299	711823	1,66	1568	3718

133% Insulation Level

CU-Tape Shielded

Size AWG or kcmil	Part no. ALU	Part no. copper	Approx. OD inch	ALU Weight approx. lb/kft	Copper Weight approx. lb/kft
6	711236	711760	0,7	241	297
4	711237	711761	0,74	276	366
2	711238	711762	0,80	326	469
1	711239	711763	0,83	356	536
1/0	711240	711764	0,90	429	656
2/0	711241	711765	0,94	476	762
3/0	711242	711766	0,99	533	894
4/0	711243	711767	1,04	601	1056
250	711244	711768	1,10	666	1203
300	711245	711769	1,15	739	1383
350	711246	711770	1,19	809	1563
400	711247	711771	1,24	879	1739
500	711248	711772	1,34	1039	2114
600	711249	711773	1,42	1180	2470
750	711250	711774	1,52	1372	2985
1000	711251	711775	1,67	1688	3838

CU Wire Shielded

Part no. ALU	Part no. copper	Approx. OD inch	ALU Weight approx. lb/kft	Copper Weight approx. lb/kft
711300	711824	0,73	224	280
711301	711825	0,78	256	345
711302	711826	0,87	339	482
711303	711827	0,90	368	548
711304	711828	0,94	405	631
711305	711829	0,98	448	734
711306	711830	1,03	502	863
711307	711831	1,08	566	1021
711308	711832	1,13	635	1172
711309	711833	1,18	704	1349
711310	711834	1,23	771	1524
711311	711835	1,27	838	1698
711312	711836	1,37	990	2066
711313	711837	1,46	1132	2423
711314	711838	1,56	1317	2930
711315	711839	1,77	1726	3876

Dimensions and specifications may be changed without prior notice.

MV-90 / MV-105 ALUMINIUM UL listed

MV-105 EPR/PVC Shielded 8KV Aluminium

100% Insulation Level

CU-Tape Shielded

Size AWG or kcmil	Part no. ALU	Part no. copper	Approx. OD inch	ALU Weight approx. lb/kft	Copper Weight approx. lb/kft
6	711252	711776	0,65	234	291
4	711253	711777	0,70	271	361
2	711254	711778	0,75	322	465
1	711255	711779	0,78	352	532
1/0	711256	711780	0,82	392	618
2/0	711257	711781	0,90	473	760
3/0	711258	711782	0,95	532	893
4/0	711259	711783	1,00	602	1057
250	711260	711784	1,06	667	1205
300	711261	711785	1,11	742	1386
350	711262	711786	1,15	814	1567
400	711263	711787	1,20	885	1744
500	711264	711788	1,30	1047	2122
600	711265	711789	1,38	1189	2480
750	711266	711790	1,48	1384	2997
1000	711267	711791	1,63	1705	3855

CU Wire Shielded

Part no. ALU	Part no. copper	Approx. OD inch	ALU Weight approx. lb/kft	Copper Weight approx. lb/kft
711316	711840	0,70	215	271
711317	711841	0,74	248	338
711318	711842	0,81	311	454
711319	711843	0,84	339	519
711320	711844	0,92	412	639
711321	711845	0,96	456	743
711322	711846	1,01	511	872
711323	711847	1,06	577	1032
711324	711848	1,12	647	1184
711325	711849	1,17	717	1362
711326	711850	1,21	785	1539
711327	711851	1,25	853	1713
711328	711852	1,35	1007	2082
711329	711853	1,44	1163	2353
711330	711854	1,55	1354	2967
711331	711855	1,77	1773	3923

133% Insulation Level

CU-Tape Shielded

Size AWG or kcmil	Part no. ALU	Part no. copper	Approx. OD inch	ALU Weight approx. lb/kft	Copper Weight approx. lb/kft
6	711268	711792	0,71	267	324
4	711269	711793	0,75	306	395
2	711270	711794	0,80	359	502
1	711271	711795	0,88	425	605
1/0	711272	711796	0,91	468	694
2/0	711273	711797	0,95	517	803
3/0	711274	711798	1,00	577	938
4/0	711275	711799	1,05	650	1104
250	711276	711800	1,11	718	1255
300	711277	711801	1,16	794	1439
350	711278	711802	1,20	868	1621
400	711279	711803	1,25	941	1801
500	711280	711804	1,35	1107	2182
600	711281	711805	1,43	1253	2544
750	711282	711806	1,53	1452	3065
1000	711283	711807	1,74	1883	4033

CU Wire Shielded

Part no. ALU	Part no. copper	Approx. OD inch	ALU Weight approx. lb/kft	Copper Weight approx. lb/kft
711332	711856	0,75	244	300
711333	711857	0,79	279	368
711334	711858	0,90	380	523
711335	711859	0,94	411	591
711336	711860	0,97	450	677
711337	711861	1,01	496	782
711338	711862	1,06	553	914
711339	711863	1,11	621	1076
711340	711864	1,17	693	1231
711341	711865	1,22	765	1410
711342	711866	1,26	836	1589
711343	711867	1,31	905	1765
711344	711868	1,41	1063	2139
711345	711869	1,49	1223	2513
711346	711870	1,60	1419	3032
711347	711871	1,82	1847	3997

MV-90 XLPE/PVC Shielded 15KV Aluminium

100% Insulation Level

CU-Tape Shielded

Size AWG or kcmil	Part no. ALU	Part no. copper	Approx. OD inch	ALU Weight approx. lb/kft	Copper Weight approx. lb/kft
2	711348	711872	0,91	406	549
1	711349	711873	0,94	438	618
1/0	711350	711874	0,97	480	707
2/0	711351	711875	1,10	528	814
3/0	711352	711876	1,06	587	948
4/0	711353	711877	1,11	658	1113
250	711354	711878	1,17	725	1262
300	711355	711879	1,22	800	1445
350	711356	711880	1,29	897	1651
400	711357	711881	1,33	970	1830
500	711358	711882	1,41	1109	2184
600	711359	711883	1,49	1253	2544
750	711360	711884	1,59	1449	3062
1000	711361	711885	1,80	1879	4029

CU Wire Shielded

Part no. ALU	Part no. copper	Approx. OD inch	ALU Weight approx. lb/kft	Copper Weight approx. lb/kft
711404	711928	0,94	382	524
711405	711929	0,97	412	591
711406	711930	1,01	450	677
711407	711931	1,05	495	781
711408	711932	1,10	551	912
711409	711933	1,15	618	1073
711410	711934	1,20	689	1226
711411	711935	1,25	760	1405
711412	711936	1,32	852	1606
711413	711937	1,37	922	1782
711414	711938	1,44	1055	2130
711415	711939	1,53	1201	2491
711416	711940	1,62	1390	3003
711417	711941	1,84	1810	3960

133% Insulation Level

CU-Tape Shielded

Size AWG or kcmil	Part no. ALU	Part no. copper	Approx. OD inch	ALU Weight approx. lb/kft	Copper Weight approx. lb/kft
2	711362	711886	1,00	472	615
1	711363	711887	1,03	506	686
1/0	711364	711888	1,06	549	776
2/0	711365	711889	1,10	600	886
3/0	711366	711890	1,15	662	1023
4/0	711367	711891	1,20	736	1191
250	711368	711892	1,28	830	1368
300	711369	711893	1,33	909	1554
350	711370	711894	1,38	985	1738
400	711371	711895	1,42	1060	1920
500	711372	711896	1,50	1203	2279
600	711373	711897	1,58	1353	2643
750	711374	711898	1,74	1656	3269
1000	711375	711899	1,92	2047	4197

CU Wire Shielded

Part no. ALU	Part no. copper	Approx. OD inch	ALU Weight approx. lb/kft	Copper Weight approx. lb/kft
711418	711942	1,03	441	583
711419	711943	1,06	472	652
711420	711944	1,10	513	740
711421	711945	1,14	561	847
711422	711946	1,19	619	980
711423	711947	1,24	689	1144
711424	711948	1,32	785	1323
711425	711949	1,37	861	1505
711426	711950	1,41	933	1687
711427	711951	1,46	1005	1865
711428	711952	1,53	1142	2218
711429	711953	1,62	1293	2584
711430	711954	1,78	1592	3205
711431	711955	1,96	1968	4118

Dimensions and specifications may be changed without prior notice.

MV-90 / MV-105 ALUMINIUM UL listed

MV-105 EPR/PVC Shielded 15KV Aluminium

100% Insulation Level

CU-Tape Shielded

Size AWG or kcmil	Part no. ALU	Part no. copper	Approx. OD inch	ALU Weight approx. lb/kft	Copper Weight approx. lb/kft
2	711376	711900	0,92	451	593
1	711377	711901	0,95	486	666
1/0	711378	711902	0,99	530	757
2/0	711379	711903	1,03	582	868
3/0	711380	711904	1,07	645	1006
4/0	711381	711905	1,12	720	1175
250	711382	711906	1,18	791	1329
300	711383	711907	1,23	871	1515
350	711384	711908	1,30	973	1726
400	711385	711909	1,34	1049	1909
500	711386	711910	1,42	1195	2270
600	711387	711911	1,51	1346	2637
750	711388	711912	1,60	1551	3163
1000	711389	711913	1,82	1995	4145

CU Wire Shielded

Part no. ALU	Part no. copper	Approx. OD inch	ALU Weight approx. lb/kft	Copper Weight approx. lb/kft
711432	711956	0,98	437	580
711433	711957	1,01	470	649
711434	711958	1,04	511	738
711435	711959	1,08	560	846
711436	711960	1,13	619	980
711437	711961	1,18	690	1145
711438	711962	1,24	766	1303
711439	711963	1,29	841	1486
711440	711964	1,36	938	1691
711441	711965	1,40	1010	1870
711442	711966	1,48	1150	2225
711443	711967	1,58	1305	2569
711444	711968	1,69	1508	3121
711445	711969	1,91	1951	4101

133% Insulation Level

CU-Tape Shielded

Size AWG or kcmil	Part no. ALU	Part no. copper	Approx. OD inch	ALU Weight approx. lb/kft	Copper Weight approx. lb/kft
2	711390	711914	1,01	532	675
1	711391	711915	1,04	569	749
1/0	711392	711916	1,08	616	843
2/0	711393	711917	1,12	671	957
3/0	711394	711918	1,16	738	1099
4/0	711395	711919	1,22	817	1272
250	711396	711920	1,29	918	1456
300	711397	711921	1,34	1002	1647
350	711398	711922	1,39	1083	1837
400	711399	711923	1,43	1163	2023
500	711400	711924	1,51	1314	2389
600	711401	711925	1,60	1472	2763
750	711402	711926	1,76	1789	3402
1000	711403	711927	1,94	2197	4347

CU Wire Shielded

Part no. ALU	Part no. copper	Approx. OD inch	ALU Weight approx. lb/kft	Copper Weight approx. lb/kft
711446	711970	1,07	511	654
711447	711971	1,10	546	726
711448	711972	1,14	591	817
711449	711973	1,18	642	928
711450	711974	1,22	705	1066
711451	711975	1,27	780	1235
711452	711976	1,35	883	1421
711453	711977	1,40	964	1608
711454	711978	1,45	1041	1794
711455	711979	1,49	1117	1977
711456	711980	1,57	1262	2338
711457	711981	1,67	1424	2715
711458	711982	1,85	1746	3359
711459	711983	2,03	2144	4294

MV-90 XLPE/PVC Shielded 25KV Aluminium

100% Insulation Level

CU-Tape Shielded

Size AWG or kcmil	Part no. ALU	Part no. copper	Approx. OD inch	ALU Weight approx. lb/kft	Copper Weight approx. lb/kft
1	711460	711984	1,10	570	749
1/0	711461	711985	1,14	616	841
2/0	711462	711986	1,18	668	953
3/0	711463	711987	1,23	733	1092
4/0	711464	711988	1,30	834	1288
250	711465	711989	1,36	907	1444
300	711466	711990	1,41	989	1633
350	711467	711991	1,45	1067	1820
400	711468	711992	1,49	1144	2003
500	711469	711993	1,57	1292	2366
600	711470	711994	1,66	1445	2735
750	711471	711995	1,82	1758	3370
1000	711472	711996	2,00	2158	4307

CU Wire Shielded

Part no. ALU	Part no. copper	Approx. OD inch	ALU Weight approx. lb/kft	Copper Weight approx. lb/kft
711512	712036	1,14	535	715
711513	712037	1,18	577	804
711514	712038	1,22	627	913
711515	712039	1,27	688	1048
711516	712040	1,34	783	1238
711517	712041	1,40	861	1399
711518	712042	1,45	939	1583
711519	712043	1,49	1014	1767
711520	712044	1,54	1087	1947
711521	712045	1,61	1229	2304
711522	712046	1,76	1487	2778
711523	712047	1,86	1692	3305
711524	712048	2,04	2078	4228

133% Insulation Level

CU-Tape Shielded

Size AWG or kcmil	Part no. ALU	Part no. copper	Approx. OD inch	ALU Weight approx. lb/kft	Copper Weight approx. lb/kft
1	711473	711997	1,23	675	854
1/0	711474	711998	1,29	747	974
2/0	711475	711999	1,33	804	1090
3/0	711476	712000	1,37	872	1233
4/0	711477	712001	1,43	953	1408
250	711478	712002	1,48	1031	1569
300	711479	712003	1,53	1116	1761
350	711480	712004	1,58	1198	1951
400	711481	712005	1,62	1278	2138
500	711482	712006	1,76	1534	2610
600	711483	712007	1,88	1748	3039
750	711484	712008	1,97	1969	3582
1000	711485	712009	2,12	2333	4483

CU Wire Shielded

Part no. ALU	Part no. copper	Approx. OD inch	ALU Weight approx. lb/kft	Copper Weight approx. lb/kft
711525	712049	-	-	-
711526	712050	1,32	702	929
711527	712051	1,36	756	1042
711528	712052	1,41	821	1181
711529	712053	1,46	898	1353
711530	712054	1,52	980	1517
711531	712055	1,57	1061	1706
711532	712056	1,61	1139	1893
711533	712057	1,66	1216	2076
711534	712058	1,79	1469	2544
711535	712059	1,91	1682	2972
711536	712060	2,01	1896	3509
711537	712061	2,16	2248	4398

Dimensions and specifications may be changed without prior notice.

MV-90 / MV-105 ALUMINIUM UL listed

MV-105 EPR/PVC Shielded 25KV Aluminium

100% Insulation Level

CU-Tape Shielded

Size AWG or kcmil	Part no. ALU	Part no. copper	Approx. OD inch	ALU Weight approx. lb/kft	Copper Weight approx. lb/kft
1	711486	712010	1,21	649	829
1/0	711487	712011	1,16	699	926
2/0	711488	712012	1,20	757	1043
3/0	711489	712013	1,25	827	1187
4/0	711490	712014	1,32	935	1390
250	711491	712015	1,38	1016	1553
300	711492	712016	1,43	1103	1748
350	711493	712017	1,47	1178	1940
400	711494	712018	1,52	1269	2129
500	711495	712019	1,59	1426	2501
600	711496	712020	1,68	1590	2881
750	711497	712021	1,84	1918	3531
1000	711498	712022	2,02	2338	4488

CU Wire Shielded

Part no. ALU	Part no. copper	Approx. OD inch	ALU Weight approx. lb/kft	Copper Weight approx. lb/kft
711538	712062	1,18	624	804
711539	712063	1,22	671	898
711540	712064	1,26	726	1012
711541	712065	1,30	792	1153
711542	712066	1,38	895	1349
711543	712067	1,43	983	1521
711544	712068	1,48	1066	1711
711545	712069	1,53	1147	1900
711546	712070	1,57	1226	2086
711547	712071	1,65	1376	2452
711548	712072	1,82	1649	2940
711549	712073	1,93	1875	3488
711550	712074	2,11	2286	4436

133% Insulation Level

CU-Tape Shielded

Size AWG or kcmil	Part no. ALU	Part no. copper	Approx. OD inch	ALU Weight approx. lb/kft	Copper Weight approx. lb/kft
1	711499	712023	1,23	713	910
1/0	711500	712024	1,30	859	1086
2/0	711501	712025	1,34	922	1208
3/0	711502	712026	1,39	997	1358
4/0	711503	712027	1,44	1086	1541
250	711504	712028	1,50	1172	1709
300	711505	712029	1,55	1264	1909
350	711506	712030	1,59	1353	2106
400	711507	712031	1,64	1440	2300
500	711508	712032	1,78	1710	2786
600	711509	712033	1,90	1939	3229
750	711510	712034	1,99	2174	3787
1000	711511	712035	2,14	2561	4711

CU Wire Shielded

Part no. ALU	Part no. copper	Approx. OD inch	ALU Weight approx. lb/kft	Copper Weight approx. lb/kft
711551	712075	1,3	746	926
711552	712076	1,36	820	1047
711553	712077	1,4	879	1165
711554	712078	1,45	951	1312
711555	712079	1,5	1036	1491
711556	712080	1,56	1130	1668
711557	712081	1,61	1219	1863
711558	712082	1,65	1304	2057
711559	712083	1,7	1387	2247
711560	712084	1,83	1655	2730
711561	712085	1,97	1882	3173
711562	712086	2,08	2122	3735
711563	712087	2,23	2501	4651

MV-90 XLPE/PVC Shielded 35KV Aluminium

100% Insulation Level

CU-Tape Shielded

Size AWG or kcmil	Part no. ALU	Part no. copper	Approx. OD inch	ALU Weight approx. lb/kft	Copper Weight approx. lb/kft
1/0	711564	712088	1,34	795	1022
2/0	711565	712089	1,38	853	1139
3/0	711566	712090	1,42	923	1284
4/0	711567	712091	1,48	1006	1461
250	711568	712092	1,53	1085	1623
300	711569	712093	1,58	1172	1817
350	711570	712094	1,63	1255	2009
400	711571	712095	1,67	1337	2197
500	711572	712096	1,81	1598	2674
600	711573	712097	1,93	1816	3107
750	711574	712098	2,02	2040	3653
1000	711575	712099	2,17	2409	4559

CU Wire Shielded

Part no. ALU	Part no. copper	Approx. OD inch	ALU Weight approx. lb/kft	Copper Weight approx. lb/kft
711612	712136	1,37	746	973
711613	712137	1,41	801	1087
711614	712138	1,46	868	1228
711615	712139	1,51	947	1401
711616	712140	1,57	1030	1568
711617	712141	1,62	1113	1758
711618	712142	1,66	1193	1946
711619	712143	1,77	1375	2235
711620	712144	1,84	1529	2604
711621	712145	1,96	1746	3036
711622	712146	2,06	1963	3576
711623	712147	2,21	2320	4470

133% Insulation Level

CU-Tape Shielded

Size AWG or kcmil	Part no. ALU	Part no. copper	Approx. OD inch	ALU Weight approx. lb/kft	Copper Weight approx. lb/kft
1/0	711576	712100	1,49	949	1176
2/0	711577	712101	1,53	1010	1296
3/0	711578	712102	1,57	1085	1446
4/0	711579	712103	1,63	1173	1627
250	711580	712104	1,74	1359	1897
300	711581	712105	1,79	1454	2098
350	711582	712106	1,84	1544	2297
400	711583	712107	1,91	1681	2541
500	711584	712108	1,99	1850	2926
600	711585	712109	2,08	2029	3320
750	711586	712110	2,17	2262	3875
1000	711587	712111	2,32	2645	4795

CU Wire Shielded

Part no. ALU	Part no. copper	Approx. OD inch	ALU Weight approx. lb/kft	Copper Weight approx. lb/kft
711624	712148	1,52	889	1116
711625	712149	1,56	947	1223
711626	712150	1,61	1018	1379
711627	712151	1,66	1102	1557
711628	712152	1,78	1295	1832
711629	712153	1,83	1385	2030
711630	712154	1,87	1472	2225
711631	712155	1,95	1604	2464
711632	712156	2,02	1767	2843
711633	712157	2,11	1947	3238
711634	712158	2,21	2175	3787
711635	712159	2,36	2545	4695

Dimensions and specifications may be changed without prior notice.

MV-90 / MV-105 ALUMINIUM UL listed

MV-105 EPR/PVC Shielded 35KV Aluminium

100% Insulation Level

CU-Tape Shielded

Size AWG or kcmil	Part no. ALU	Part no. copper	Approx. OD inch	ALU Weight approx. lb/kft	Copper Weight approx. lb/kft
1/0	711588	712112	1,36	920	1147
2/0	711589	712113	1,40	984	1270
3/0	711590	712114	1,44	1061	1422
4/0	711591	712115	1,49	1153	1607
250	711592	712116	1,55	1241	1778
300	711593	712117	1,60	1335	1980
350	711594	712118	1,65	1426	2179
400	711595	712119	1,75	1619	2479
500	711596	712120	1,83	1791	2867
600	711597	712121	1,95	2025	3315
750	711598	712122	2,04	2264	3877
1000	711599	712123	2,19	2658	4808

CU Wire Shielded

Part no. ALU	Part no. copper	Approx. OD inch	ALU Weight approx. lb/kft	Copper Weight approx. lb/kft
711636	712160	1,41	881	1108
711637	712161	1,45	942	1228
711638	712162	1,50	1016	1376
711639	712163	1,55	1103	1558
711640	712164	1,61	1199	1737
711641	712165	1,66	1290	1934
711642	712166	1,77	1482	2236
711643	712167	1,81	1580	2430
711644	712168	1,89	1736	2812
711645	712169	2,02	1969	3260
711646	712170	2,13	2214	3827
711647	712171	2,28	2599	4749

133% Insulation Level

CU-Tape Shielded

Size AWG or kcmil	Part no. ALU	Part no. copper	Approx. OD inch	ALU Weight approx. lb/kft	Copper Weight approx. lb/kft
1/0	711600	712124	1,51	1115	1341
2/0	711601	712125	1,55	1184	1470
3/0	711602	712126	1,60	1267	1628
4/0	711603	712127	1,65	1365	1820
250	711604	712128	1,76	1565	2103
300	711605	712129	1,81	1669	2314
350	711606	712130	1,86	1769	2522
400	711607	712131	1,94	1919	2776
500	711608	712132	2,01	2100	3176
600	711609	712133	2,10	2296	3586
750	711610	712134	2,19	2548	4161
1000	711611	712135	2,35	2960	5110

CU Wire Shielded

Part no. ALU	Part no. copper	Approx. OD inch	ALU Weight approx. lb/kft	Copper Weight approx. lb/kft
711648	712172	1,57	1064	1291
711649	712173	1,61	1130	1416
711650	712174	1,65	1210	1570
711651	712175	1,77	1409	1864
711652	712176	1,82	1516	2053
711653	712177	1,87	1616	2260
711654	712178	1,92	1711	2465
711655	712179	1,99	1853	2713
711656	712180	2,07	2031	3106
711657	712181	2,17	2229	3519
711658	712182	2,29	2487	4100
711659	712183	2,44	2892	5042

Dimensions and specifications may be changed without prior notice.

SPECIAL ALUMINIUM CABLES



HELUWIND® WK ALU Tower

0,6/1kV



Technical Data

- **Temperature range**
fixed installation -40°C up to +90°C
flexing -25°C up to +50°C
- **Operating temperature at conductor**
max. +90°C
- **Nominal voltage**
0,6/1 kV (50Hz)
- **Test voltage**
4 kV (50Hz)
- **Minimum bending radius**
5 x cable diameter
- **Approvals**
Flame test IEC 60332-1
acc. to IEC 60502-1

Cable structure

- Aluminium conductor, stranded/round shaped (RM), acc. to IEC 60228, Cl. 2 (nv)
- Soft annealed aluminium conductor
- Insulation: EPR compound, black
- Sheath: special PCP compound
- Sheath colour: black

Properties

- UV resistant
- Oil resistant

Application

For medium mechanical stress in dry, damp, wet environments and outdoors; particularly as a power cable in wind turbines, for fixed installations in the tower or lattice tower. Due to the special cable structure, and outer sheath, this cable provides a relative flexibility compared to standard cables (NAYY-NA2XY-NA2XH). Thanks to its increased flexibility, this cable is perfectly suited for connecting wind turbines and external substations (pipes). The cable is also available with a rated voltage of 1,8/3 kV.

CE = The product conforms with the EC Low-Voltage Directive 2006/95/EC.

Part no.	No. cores x cross-sec. mm²	AWG no.	Outer-Ø approx. mm	AL weight approx. kg/km	Weight approx. kg/km	Price EUR/100m AL 0,-
708470	1 x 150	300 kcmil	23	435	790	on request
708471	1 x 185	350 kcmil	26	537	960	on request
709957	1 x 240	500 kcmil	27	696	1208	on request
708473	1 x 300	600 kcmil	29	870	1342	on request
708474	1 x 400	750 kcmil	31,4	1160	1843	on request

Dimensions and specifications may be changed without prior notice.

CONNECTION TECHNOLOGY



■ ALUMINIUM AS A CONDUCTOR MATERIAL

The material characteristics of aluminium are considerably different than those of copper. These differences must be taken into consideration when processing a cable and selecting connection components.

Oxidation in the air

When exposed to oxygen, a hard and resistant oxide coating forms within a short period of time on the surface of aluminium. The coating protects the subjacent material from further corrosion. This effect makes aluminium a highly durable material. However, the protective oxide coating on the material surface is not desirable when it comes to electrical engineering. It degrades the conductivity of the aluminium and makes contacting difficult. If an oxidised conductor is connected without any pretreatment (to remove the coating), the contact resistance will be increased between the aluminium conductor and the connector component. This can result in temperature increases and, under worst-case conditions, cable fires.

To prevent such problems, the oxide coating must be broken or removed physically. This can be done by brushing the bare aluminium conductor ends before contacts are made and also during the crimping process: Connector components for aluminium conductors are equipped with special contact grease from the factory, usually a grainy, abrasive material such as corundum. Combined with high pressure, the corundum particles cause an abrasive effect that breaks the nonconductive oxide coating on the aluminium, improving contact properties and electrical connections. The grease also prevents moisture and oxygen from entering and causing anew corrosion of the contact points. Better quality cable lugs are generally equipped with plastic plugs, which prevent the contact grease from drying out or leaking during storage.

Optimal contacting with C8 crimping

For fine-wire conductor designs, we recommend that IEC 61238-1 Cl. A-tested C8 crimps be used due to the larger oxidising surface of the conductor. C8 crimp's contours penetrate very deeply into a stranded bundle, equally tear up the individual strands, and thus allow for optimum contacts on all strands, even in the bundle core. The use of C8 crimps (that have been developed as part of the POWERLINE Aluminium series) allows for the best possible electrical values (low contact resistance) and mechanical extraction forces to be reached.

Compatibility with electrochemical precious metals

When it comes to specifying electrical connection components, the corrosive reactions of aluminium in the presence of other

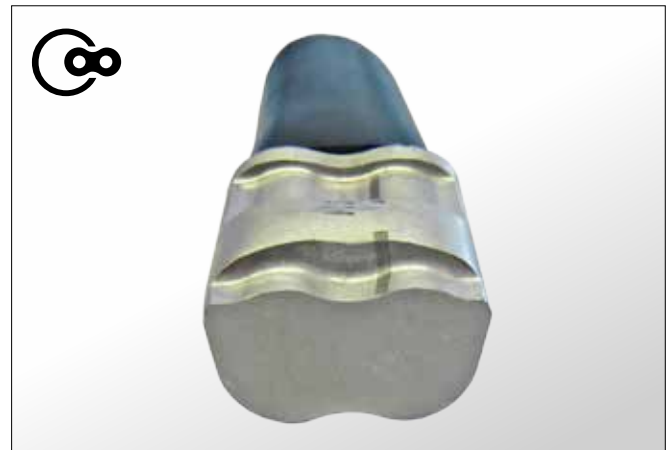

A C8 crimping's pressing pattern shows equal conductor distribution in the cable lug.

metals – mainly copper – must also be taken into consideration. When aluminium comes into contact with more noble metals (metals with higher electropotential) such as copper, iron, or brass, an electrochemical reaction may arise by means of contact element formation. This reaction is activated by conductive liquids – in the field mostly by condensed water (condensation). In this process, the potential differences produced by the electrochemical voltage series play a crucial role. The copper electrode (anode), electrolyte (water), and the aluminium electrode (cathode) create a contact element. Any voltage across these elements is short-circuited by the contact between the copper and aluminium. The resulting current creates a decomposition process in the aluminium, which is visible as a radiant oxidation point revealing the contamination of tiny copper particles. However, the copper does not decompose. But the decomposition process negatively affects the electrical connection over the long term, with increasing contact resistances that lead to temperature increases and even to fires. Therefore, we recommend using an aluminium/copper (Al/Cu) cable lug for connecting aluminium to copper peripherals. Bimetal connectors such as Al/Cu cable lugs, press connectors and connecting bolt pins are manufactured using a friction welding process. They are encapsulated to prevent liquids from penetrating the connection and causing any unwanted creepage. The use of Al/Cu connectors and connections is the most sensible way of combating the effects of oxidation on aluminium. Another means of protecting against moisture is installing a secondary insulation on the contact area. Depending on the field of application, mechanical load, and environmental conditions, a cold-, a roll-, or a hot-shrink tube can be used. The best protection results are achieved by shrink tubes with inside adhesive. At the same time, the electrical contacts should be thoroughly inspected during regularly scheduled maintenance.

■ ALUMINIUM AS A CONDUCTOR MATERIAL

Decreasing connection strength due to creepage

Finally, the creepage behaviour of aluminium is something that must be considered. Aluminium is a softer metal than copper and tends to expand or stretch over time, especially when subjected to higher pressure and temperature. Classic crimp connections suffering from creepage lose strength and would no longer be reliable to ensure proper connectivity. HELUKABEL's C8 crimp exhibits a filling degree of 95 percent, which can not be obtained with conventional crimp connections. The described expansion/stretch process is compensated with outstanding extraction values. At the same time, we recommend performing regular maintenance and inspection on all clamping points in accordance with their load levels.



C8-Crimp Connection



C8-Crimp

HELU-S-PK-AL-DIN Aluminium compression cable lug - straight



Compression cable lug HELU-S-PK-AL-DIN

Uninsulated, straight tubular cable lug in eye type design made of aluminium. High quality version for reliable crimping. Designed for conductor type RM acc. to DIN 48201 and circularly reshaped conductors.

Material

AL 99,5
Surface: bare

Note

- Code type indicates the required hexagonal crimping insert.
- Sleeves are prefilled with contact grease and sealed with plastic plug

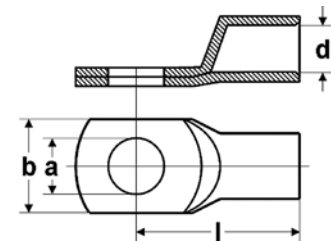

Dimensions

- a Diameter of the bore
- d Inner diameter of the cable inclusion
- b Flange width
- l Length to middle of the bore

Part no.	Type	Cross-section RM/SM - SE mm ²	a mm	d mm	b mm	l mm	Code type	Weight kg / 1000 items	Unit	Net EUR/100 items at a purchase of		
										up to 100	101 - 500	501 - 1000
907865	HELU-S-PK-AL-DIN 16-8	16,0 - 25,0	8,4	5,6	16,0	52,0	12	9,6	50	o. r.	o. r.	o. r.
907866	HELU-S-PK-AL-DIN 16-10	16,0 - 25,0	10,5	5,6	18,0	52,0	12	9,7	50	o. r.	o. r.	o. r.
907867	HELU-S-PK-AL-DIN 25-8	25,0 - 35,0	8,4	6,8	16,0	60,0	12	14,8	50	o. r.	o. r.	o. r.
907868	HELU-S-PK-AL-DIN 25-10	25,0 - 35,0	10,5	6,8	18,0	60,0	12	15,3	50	o. r.	o. r.	o. r.
907869	HELU-S-PK-AL-DIN 35-8	35,0 - 50,0	8,4	8,0	20,0	67,0	14	24,5	50	o. r.	o. r.	o. r.
907870	HELU-S-PK-AL-DIN 35-10	35,0 - 50,0	10,5	8,0	20,0	67,0	14	24,5	50	o. r.	o. r.	o. r.
907871	HELU-S-PK-AL-DIN 35-12	35,0 - 50,0	13,0	8,0	20,0	67,0	14	23,5	50	o. r.	o. r.	o. r.
907872	HELU-S-PK-AL-DIN 50-8	50,0 - 70,0	8,4	10,0	23,0	74,0	16	32,9	25	o. r.	o. r.	o. r.
907873	HELU-S-PK-AL-DIN 50-10	50,0 - 70,0	10,5	10,0	23,0	74,0	16	28,8	25	o. r.	o. r.	o. r.
907874	HELU-S-PK-AL-DIN 50-12	50,0 - 70,0	13,0	10,0	23,0	74,0	16	33,8	25	o. r.	o. r.	o. r.
907875	HELU-S-PK-AL-DIN 70-10	70,0 - 95,0	10,5	11,5	28,0	84,0	18	47,7	25	o. r.	o. r.	o. r.
907876	HELU-S-PK-AL-DIN 70-12	70,0 - 95,0	13,0	11,5	28,0	87,0	18	47,3	25	o. r.	o. r.	o. r.
907877	HELU-S-PK-AL-DIN 95-10	95,0 - 120,0	10,5	13,2	32,0	90,0	22	70,1	10	o. r.	o. r.	o. r.
907878	HELU-S-PK-AL-DIN 95-12	95,0 - 120,0	13,0	13,2	32,0	90,0	22	78,2	10	o. r.	o. r.	o. r.
907879	HELU-S-PK-AL-DIN 95-16	95,0 - 120,0	17,0	13,2	32,0	90,0	22	76,2	10	o. r.	o. r.	o. r.
907880	HELU-S-PK-AL-DIN 120-10	120,0 - 150,0	10,5	14,7	32,0	98,0	22	83,8	10	o. r.	o. r.	o. r.
907881	HELU-S-PK-AL-DIN 120-12	120,0 - 150,0	13,0	14,7	32,0	98,0	22	87,9	10	o. r.	o. r.	o. r.
907882	HELU-S-PK-AL-DIN 120-16	120,0 - 150,0	17,0	14,7	32,0	98,0	22	86,4	10	o. r.	o. r.	o. r.
906459	HELU-S-PK-AL-DIN 150-10	150,0 - 185,0	10,5	16,3	35,0	104,0	25	99,8	10	o. r.	o. r.	o. r.
906436	HELU-S-PK-AL-DIN 150-12	150,0 - 185,0	13,0	16,3	35,0	104,0	25	102,3	10	o. r.	o. r.	o. r.
906461	HELU-S-PK-AL-DIN 150-16	150,0 - 185,0	13,0	16,3	35,0	104,0	25	100,8	10	o. r.	o. r.	o. r.
906462	HELU-S-PK-AL-DIN 150-20	150,0 - 185,0	21,0	16,3	35,0	104,0	25	100,2	10	o. r.	o. r.	o. r.
907883	HELU-S-PK-AL-DIN 185-10	185,0 - 240,0	10,5	18,5	40,0	109,0	28	133,9	10	o. r.	o. r.	o. r.
906463	HELU-S-PK-AL-DIN 185-12	185,0 - 240,0	13,0	18,5	40,0	109,0	28	133,9	10	o. r.	o. r.	o. r.
906464	HELU-S-PK-AL-DIN 185-16	185,0 - 240,0	17,0	18,5	40,0	109,0	28	137,5	10	o. r.	o. r.	o. r.
906465	HELU-S-PK-AL-DIN 185-20	185,0 - 240,0	21,0	18,5	40,0	109,0	28	137,5	10	o. r.	o. r.	o. r.
907884	HELU-S-PK-AL-DIN 240-10	240,0 - 300,0	10,5	21,0	46,0	119,0	32	182,8	10	o. r.	o. r.	o. r.
906466	HELU-S-PK-AL-DIN 240-12	240,0 - 300,0	13,0	21,0	46,0	119,0	32	179,4	10	o. r.	o. r.	o. r.
906467	HELU-S-PK-AL-DIN 240-16	240,0 - 300,0	17,0	21,0	46,0	119,0	32	176,2	10	o. r.	o. r.	o. r.
906468	HELU-S-PK-AL-DIN 240-20	240,0 - 300,0	21,0	21,0	46,0	119,0	32	179,0	10	o. r.	o. r.	o. r.
906469	HELU-S-PK-AL-DIN 300-12	300,0	13,0	23,3	50,0	125,0	38	205,4	5	o. r.	o. r.	o. r.
906470	HELU-S-PK-AL-DIN 300-16	300,0	17,0	23,3	50,0	125,0	38	201,4	5	o. r.	o. r.	o. r.
906471	HELU-S-PK-AL-DIN 300-20	300,0	21,0	23,3	50,0	125,0	38	194,3	5	o. r.	o. r.	o. r.
906472	HELU-S-PK-AL-DIN 400-12	400,0	13,0	26,6	55,0	120,0	38	283,0	5	o. r.	o. r.	o. r.
906473	HELU-S-PK-AL-DIN 400-16	400,0	17,0	26,6	55,0	120,0	38	273,3	5	o. r.	o. r.	o. r.
906474	HELU-S-PK-AL-DIN 400-20	400,0	21,0	26,6	55,0	120,0	38	240,0	5	o. r.	o. r.	o. r.
906475	HELU-S-PK-AL-DIN 500-12	500,0	13,0	29,0	63,0	140,0	44	380,0	5	o. r.	o. r.	o. r.
906476	HELU-S-PK-AL-DIN 500-16	500,0	17,0	29,0	63,0	140,0	44	378,0	5	o. r.	o. r.	o. r.
906477	HELU-S-PK-AL-DIN 500-20	500,0	21,0	29,0	63,0	140,0	44	373,5	5	o. r.	o. r.	o. r.

Dimensions and specifications may be changed without prior notice.

o. r. = on request

HELU-S-PK-AL-FG compression cable lug, FG, extruded, straight ring design



Technical Data

Material: Aluminium AL 99,5
Surface: bare or tinned
Special feature: smaller connecting flange (b) than DIN compression cable lugs

Note

- Sleeve filled with contact grease and sealed with plastic plug
- Strain-relieved for aluminium conductors
- DIN 46329

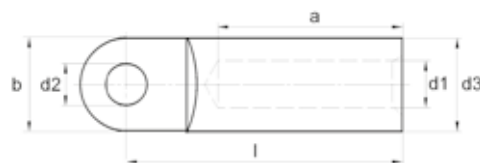

HELU-S-PK-AL-FG

Part no. bright	Cross section mm ² / sm*	Hole M	Key figures	Dimension in mm					
				d1	d3	d2	b	l	a
906539	95	10	22	13,2	22,0	10,5	25	75	56
906540	95	12	22	13,2	22,0	13,0	25	75	56
906541	120	10	22	14,7	14,7	10,5	30	80	56
906542	120	12	22	14,7	14,7	13,0	30	80	56
906543	120	16	22	14,7	14,7	17,0	30	80	56
906544	150	10	25	16,3	25,0	10,5	30	90	60
906545	150	12	25	16,3	25,0	13,0	30	90	60
906546	150	16	25	16,3	25,0	17,0	30	90	60
906547	185	10	28	18,3	28,5	10,5	30	91	60
906548	185	12	28	18,3	28,5	13,0	30	91	60
906549	185	16	28	18,3	28,5	17,0	30	91	60
906550	240	12	32	21,0	32,0	13,0	38	103	70
906551	240	16	32	21,0	32,0	17,0	38	103	70
906552	240	20	32	21,0	32,0	21,0	38	103	70
906553	300	12	34	23,3	34,0	13,0	38	103	70
906554	300	16	34	23,3	34,0	17,0	38	103	70
906555	300	20	34	23,3	34,0	21,0	38	103	70
906556	400	12	38	26,0	38,5	13,0	38	116	73
906557	400	16	38	26,0	38,5	17,0	38	116	73
906558	400	20	38	26,0	38,5	21,0	38	116	73
906559	500	12	44	29,0	44,0	13,0	44	122	79
906560	500	16	44	29,0	44,0	17,0	44	122	79
906561	500	20	44	29,0	44,0	21,0	44	122	79

rm = round cable multi-wire
 sm = sector cable multi-wire

Other dimensions available on request. Subject to technical changes.
 Prices available on request.

HELU-S-PK-AL/CU Aluminium/copper compression cable lug - straight



Compression cable lug HELU-S-PK-AL/CU

Non-insulated, straight compression lug in eye type design made of aluminium. High quality version for reliable crimping. Designed for conductor type RM and circular reshaped conductors.

Material

Socket: Al 99,5 and Cu acc. to DIN EN 13601
Surface: bare

Note

- Code type indicates the required hexagonal crimping insert.
- Al-sleeves are prefilled with contact grease and sealed with plastic plugs

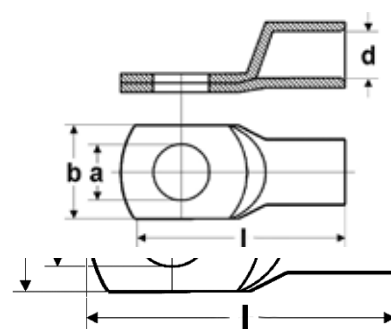

Dimensions

- a Boring diameter
- d Inner diameter of the cable inclusion
- b Flange width

Part no.	Cross-section mm ²		Drilling M	a mm	d mm	b mm	l mm	Code Typ	Weight kg/1000 items	Unit	Net EUR/100 items at a purchase of		
	rm/sm	se									up to 500	501-1000	1001-5000
907568	10	-	8	8,4	5,0	20	50	10	26,5	25	o.r.	o.r.	o.r.
907569	16	25	8	8,4	5,6	20	60	12	35,4	25	o.r.	o.r.	o.r.
907570	16	25	10	10,5	5,6	20	60	12	34,2	25	o.r.	o.r.	o.r.
907571	25	35	8	8,4	6,8	20	65	12	35,7	25	o.r.	o.r.	o.r.
907572	25	35	10	10,5	6,8	20	65	12	34,4	25	o.r.	o.r.	o.r.
907573	25	35	12	13,0	6,8	26	67	12	44,5	25	o.r.	o.r.	o.r.
907574	35	50	8	8,4	8,0	20	75	14	45,5	25	o.r.	o.r.	o.r.
907575	35	50	10	10,5	8,0	20	75	14	44,2	25	o.r.	o.r.	o.r.
907576	35	50	12	13,0	8,0	26	75	14	51,5	25	o.r.	o.r.	o.r.
907577	50	70	8	8,4	9,8	20	75	16	48,7	25	o.r.	o.r.	o.r.
907578	50	70	10	10,5	9,8	20	75	16	47,2	25	o.r.	o.r.	o.r.
907579	50	70	12	13,0	9,8	26	75	16	59,9	25	o.r.	o.r.	o.r.
907580	70	95	8	8,4	11,2	26	85	18	61,9	10	o.r.	o.r.	o.r.
907581	70	95	10	10,5	11,2	26	85	18	73,7	10	o.r.	o.r.	o.r.
907582	70	95	12	13,0	11,2	26	85	18	73,7	10	o.r.	o.r.	o.r.
907583	70	95	16	17,0	11,2	30	88	18	81,0	10	o.r.	o.r.	o.r.
907584	95	120	8	8,4	13,2	26	86	22	102,9	10	o.r.	o.r.	o.r.
907585	95	120	10	10,5	13,2	26	86	22	105,9	10	o.r.	o.r.	o.r.
907586	95	120	12	13,0	13,2	26	86	22	103,4	10	o.r.	o.r.	o.r.
907587	95	120	16	17,0	13,2	30	88	22	109,9	10	o.r.	o.r.	o.r.
907588	120	150	8	8,4	14,7	26	88	22	106,8	10	o.r.	o.r.	o.r.
907589	120	150	10	10,5	14,7	26	88	22	106,8	10	o.r.	o.r.	o.r.
907590	120	150	12	13,0	14,7	26	88	22	104,5	10	o.r.	o.r.	o.r.
907591	120	150	16	17,0	14,7	30	90	22	114,5	10	o.r.	o.r.	o.r.
907592	150	185	8	8,4	16,3	30	100	25	138,8	5	o.r.	o.r.	o.r.
906478	150	185	10	10,5	16,3	30	100	25	138,0	5	o.r.	o.r.	o.r.
906172	150	185	12	13,0	16,3	30	100	25	135,7	5	o.r.	o.r.	o.r.
906173	150	185	16	17,0	16,3	30	100	25	128,8	5	o.r.	o.r.	o.r.
907593	185	240	8	8,4	18,3	30	102	28	183,7	5	o.r.	o.r.	o.r.
906479	185	240	10	10,5	18,3	30	102	28	176,1	5	o.r.	o.r.	o.r.
906480	185	240	12	13,0	18,3	30	102	28	173,1	5	o.r.	o.r.	o.r.
906481	185	240	16	17,0	18,3	36	105	28	196,8	5	o.r.	o.r.	o.r.
906482	185	240	8	21,0	18,3	36	105	28	189,7	5	o.r.	o.r.	o.r.
906483	240	300	10	10,5	21,0	30	112	32	204,1	5	o.r.	o.r.	o.r.
906185	240	300	12	13,0	21,0	30	112	32	204,1	5	o.r.	o.r.	o.r.
906484	240	300	16	17,0	21,0	36	115	32	225,8	5	o.r.	o.r.	o.r.
906485	240	300	20	21,0	21,0	36	115	32	218,5	5	o.r.	o.r.	o.r.
906486	300	-	10	10,5	23,3	30	115	34	218,4	5	o.r.	o.r.	o.r.
906487	300	-	12	13,0	23,3	30	116	34	226,4	5	o.r.	o.r.	o.r.
906488	300	-	16	17,0	23,3	36	116	34	232,2	5	o.r.	o.r.	o.r.
906489	300	-	20	21,0	23,3	36	116	34	225,0	5	o.r.	o.r.	o.r.
906490	400	-	10	10,5	26,0	36	125	38	328,7	5	o.r.	o.r.	o.r.

HELU-S-PK-AL/CU Copper compression cable lug – straight

Part no.	Cross-section mm ²		Drilling M	a mm	d mm	b mm	l mm	Code Typ	Weight kg/1000 items	Unit	Net EUR/100 items at a purchase of		
	rm/sm	se									up to 500	501-1000	1001-5000
906212	400	-	12	13,0	26,0	36	125	38	332,7	5	o.r.	o.r.	o.r.
906174	400	-	16	17,0	26,0	36	125	38	352,6	5	o.r.	o.r.	o.r.
906175	400	-	20	21,0	26,0	36	125	38	341,5	5	o.r.	o.r.	o.r.
906491	500	-	10	10,5	29,0	44	140	44	437,1	1	o.r.	o.r.	o.r.
906492	500	-	12	13,0	29,0	44	140	44	433,3	1	o.r.	o.r.	o.r.
906493	500	-	16	17,0	29,0	44	140	44	428,3	1	o.r.	o.r.	o.r.
906494	500	-	20	21,0	29,0	44	140	44	420,8	1	o.r.	o.r.	o.r.
907594	625	-	12	13,0	35,0	50	177	52	630,1	1	o.r.	o.r.	o.r.
907595	625	-	16	17,0	35,0	50	177	52	770,0	1	o.r.	o.r.	o.r.
907596	625	-	20	21,0	35,0	50	177	52	763,0	1	o.r.	o.r.	o.r.

HELU-S-PV-AL-DIN Aluminium press connector



Press connector HELU-S-PV-AL-DIN

Press connector for strain-relieved connections of conductors designed acc. to DIN 46267 part 2.

Material

Socket: Al 99,5
Surface: bare

Note

- Code type indicates the required hexagonal crimping insert.
- Part No. 907835 is not standardized.
- Sleeves are prefilled with contact grease and sealed with plastic plug.

Technical data

Temperature range: up to +120°C

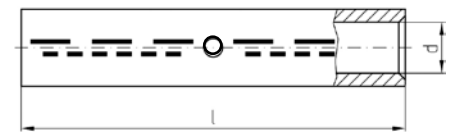

Dimensions

d Inner diameter of the cable inclusion
l Length

Part no.	Cross-section mm ²		d mm	l mm	Code Typ	Gewicht kg/1000 Items	Unit	Net EUR/100 Items at a purchase of		
	rm/sm	se						up to 500	501-1000	1001-5000
907835	16	25	5,6	55	12	13,4	50	108,20	100,40	77,30
906511	25	35	6,8	70,0	12	15,4	50	110,70	102,80	79,10
906512	35	50	8,0	85,0	14	28,5	50	114,50	106,30	81,80
906513	50	70	10,0	85,0	16	34,0	25	130,40	121,10	93,10
906514	70	95	11,5	105,0	18	55,9	25	168,80	156,70	120,60
906515	95	120	13,2	105,0	22	82,1	10	230,00	213,60	164,30
906516	120	150	14,7	105,0	22	86,4	10	232,20	215,60	165,80
906406	150	185	16,3	125,0	25	111,3	10	263,60	244,80	188,30
906517	185	240	18,5	125,0	28	143,5	10	392,20	364,20	280,20
906518	240	300	21,0	145,0	32	191,7	10	478,60	444,40	341,90
906519	300	-	23,3	145,0	34	227,1	10	858,60	797,30	613,30
906520	400	-	26,0	210,0	38	359,0	5	2042,90	1897,00	1459,20
906521	500	-	29,0	210,0	44	455,0	5	2311,30	2146,20	1650,90

HELU-S-PV-AL/CU Aluminium / Copper press connector



Press Connector HELU-S-PV-AL/ CU

Press connector for aluminium conductors, strain relieved

Material

Socket: Al 99,5 and Cu acc. to DIN EN 13601
Surface: bare

Note

Al-sleeves are pre-filled with contact grease and sealed with plastic plug.

Technical data

Temperature range: up to +120°C

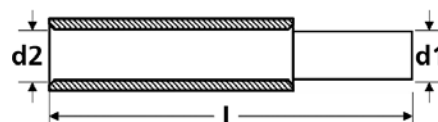

Dimensions

d1 Inner diameter of the cable inclusion, copper side

d2 Inner diameter of the cable inclusion, aluminium side

l Length

Part no.	Cross-section AL RM/SM - SE mm ²	Cross-section CU SE mm ²	Code type AL / CU	d1 CU mm	d2 AL mm	l mm	Weight kg / 1000 items	Unit	Net EUR/100 items at a purchase of		
									up to 100	101 - 500	501 - 1000
907836	16 - 25	6	12 / 5	3,7	5,6	45,0	9,2	25	o. r.	o. r.	o. r.
907837	16 - 25	10	12 / 6	4,4	5,6	45,0	9,4	25	o. r.	o. r.	o. r.
907838	16 - 25	16	12 / 8	5,5	5,6	56,0	15,8	25	o. r.	o. r.	o. r.
907839	25 - 35	10	12 / 6	4,4	6,8	51,0	9,9	25	o. r.	o. r.	o. r.
907840	25 - 35	16	12 / 8	5,5	6,8	61,0	16,1	25	o. r.	o. r.	o. r.
907841	25 - 35	25	12 / 10	7,0	6,8	62,0	19,2	25	o. r.	o. r.	o. r.
907842	35 - 50	16	14 / 8	5,5	8,0	71,0	21,2	25	o. r.	o. r.	o. r.
907843	35 - 50	25	14 / 10	7,0	8,0	71,0	24,1	25	o. r.	o. r.	o. r.
907844	35 - 50	35	14 / 12	8,2	8,0	70,0	29,9	25	o. r.	o. r.	o. r.
907845	50 - 70	25	16 / 10	7,0	9,8	71,5	26,6	25	o. r.	o. r.	o. r.
907846	50 - 70	35	16 / 12	8,2	9,8	71,5	33,4	25	o. r.	o. r.	o. r.
907847	50 - 70	50	16 / 14	10,0	9,8	71,5	43,5	25	o. r.	o. r.	o. r.
907848	70 - 95	25	18 / 10	7,0	11,2	79,0	36,2	10	o. r.	o. r.	o. r.
907849	70 - 95	35	18 / 12	8,2	11,2	79,0	42,2	10	o. r.	o. r.	o. r.
907850	70 - 95	50	18 / 14	10,0	11,2	85,0	53,3	10	o. r.	o. r.	o. r.
907851	70 - 95	70	18 / 16	11,5	11,2	88,0	64,0	10	o. r.	o. r.	o. r.
907852	95 - 120	35	22 / 12	8,2	13,2	79,0	57,4	10	o. r.	o. r.	o. r.
907853	95 - 120	50	22 / 14	10,0	13,2	85,0	69,1	10	o. r.	o. r.	o. r.
907854	95 - 120	70	22 / 16	11,5	13,2	87,0	78,9	10	o. r.	o. r.	o. r.
907855	95 - 120	95	22 / 18	13,5	13,2	94,0	98,8	10	o. r.	o. r.	o. r.
907856	120 - 150	50	22 / 14	10,0	14,7	87,0	66,5	10	o. r.	o. r.	o. r.
907857	120 - 150	70	22 / 16	11,5	14,7	89,0	76,1	10	o. r.	o. r.	o. r.
907858	120 - 150	95	22 / 18	13,5	14,7	97,0	97,7	10	o. r.	o. r.	o. r.
907859	120 - 150	120	22 / 20	15,5	14,7	98,0	108,3	10	o. r.	o. r.	o. r.
906460	150 - 185	70	25 / 16	11,5	16,3	101,0	95,9	5	o. r.	o. r.	o. r.
906495	150 - 185	95	25 / 18	13,5	16,3	108,0	116,6	5	o. r.	o. r.	o. r.
906209	150 - 185	120	25 / 20	15,5	16,3	108,0	125,9	5	o. r.	o. r.	o. r.
906496	150 - 185	150	25 / 22	17,0	16,3	113,0	155,0	5	o. r.	o. r.	o. r.
906497	185 - 240	95	28 / 18	13,5	18,3	108,0	130,0	5	o. r.	o. r.	o. r.
906498	185 - 240	120	28 / 20	15,5	18,3	108,0	140,1	5	o. r.	o. r.	o. r.
906499	185 - 240	150	28 / 22	17,0	18,3	113,0	169,3	5	o. r.	o. r.	o. r.
906500	185 - 240	185	28 / 25	19,0	18,3	116,0	185,3	5	o. r.	o. r.	o. r.
906501	240 - 300	120	32 / 20	15,5	21,0	120,0	173,6	5	o. r.	o. r.	o. r.
906502	240 - 300	150	32 / 22	17,0	21,0	124,0	200,8	5	o. r.	o. r.	o. r.
906503	240 - 300	185	32 / 25	19,0	21,0	127,0	218,4	5	o. r.	o. r.	o. r.
906504	240 - 300	240	32 / 28	21,5	21,0	132,0	280,0	5	o. r.	o. r.	o. r.
906505	300 - -	150	34 / 22	17,0	23,3	124,0	205,1	5	o. r.	o. r.	o. r.
906506	300 - -	185	34 / 25	19,0	23,3	128,0	225,8	5	o. r.	o. r.	o. r.
906507	300 - -	240	34 / 28	21,5	23,3	134,0	290,0	5	o. r.	o. r.	o. r.
906508	300 - -	300	34 / 32	24,5	23,3	144,0	349,0	5	o. r.	o. r.	o. r.
906509	400 - -	185	38 / 25	19,0	26,0	131,0	267,0	1	o. r.	o. r.	o. r.
906210	400 - -	240	38 / 28	21,5	26,0	135,0	329,0	1	o. r.	o. r.	o. r.
906510	400 - -	300	38 / 32	24,5	26,0	145,0	386,0	1	o. r.	o. r.	o. r.
907860	500 - -	240	44 / 28	21,5	29,0	145,0	402,0	1	o. r.	o. r.	o. r.
907861	500 - -	300	44 / 32	24,5	29,0	155,0	464,1	1	o. r.	o. r.	o. r.
907862	500 - -	400	44 / 38	27,5	29,0	173,0	643,6	1	o. r.	o. r.	o. r.

Dimensions and specifications may be changed without prior notice.

o. r. = on request

HELU-S-PAB-AL-DIN Aluminium Compression Terminal Pin Type



Aluminium Compression Terminal Pin Type

HELU-S-PAB-AL-DIN

Material

- Aluminium Alloy 99,5

Note

- Code type indicates the required hexagonal crimp insert
- AL-sleeves are prefilled with contact grease and sealed with plastic plug

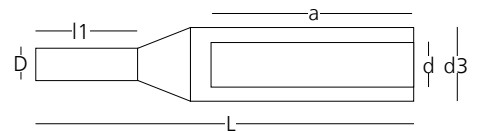

Dimensions

- a depth of bore
- d inner diameter, tube
- d3 outer diameter, tube
- D outer diameter, pin
- l1 bolt length
- L total length

Part no.	Type	cross section		a	d	d3	D	l1	L	key figures	
		mm	mm ²							mm	Type
908301	HELU-S-PAB-AL-DIN 50	50	70	41,0	9,8	16,0	8	25	77	16	
908302	HELU-S-PAB-AL-DIN 70	70	95	48,0	11,2	18,5	10	30	89	18	
908303	HELU-S-PAB-AL-DIN 95	95	120	48,0	13,2	22,0	12	33	93	22	
908304	HELU-S-PAB-AL-DIN 120	120	150	49,0	14,7	23,0	13	38	100	22	
908305	HELU-S-PAB-AL-DIN 150	150	185	58,5	16,3	25,0	14	38	110	25	
908306	HELU-S-PAB-AL-DIN 185	185	240	58,5	18,3	28,5	16	44	120	28	
908307	HELU-S-PAB-AL-DIN 240	240	300	69,0	21,0	32,0	18	44	130	32	
908308	HELU-S-PAB-AL-DIN 300	300	-	69,0	23,3	34,0	20	46	132	34	
908309	HELU-S-PAB-AL-DIN 400	400	-	70,0	26,0	38,5	23	52	140	38	
908310	HELU-S-PAB-AL-DIN 500	500	-	80,0	29,0	44,0	26	58	156	44	

HELU-S-PAB-AL/CU-DIN Bimetallic Compression Terminal Pin Type



RoHS

Bimetallic Compression Terminal Pin Type

HELU-S-PAB-AL/CU-DIN

Material

- Aluminium Alloy 99,5 (tube) and bare copper (pin) according to DIN EN 13601
- Surface: bare

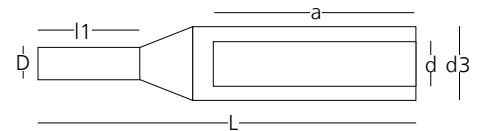

Note

- Code type indicates the required hexagonal crimp insert
- AL-sleeves are prefilled with contact grease and sealed with plastic plug

Dimensions

- a depth of bore
- d inner diameter, tube
- d3 outer diameter, tube
- D outer diameter, pin
- l1 bolt length
- L total length

Part no.	Type	cross section		a	d	d3	D	l1	L	key figures	Weight	Unit
		mm ²	se									
908191	HELU-S-PAB-AL/CU-DIN 16	16	35	26,0	5,6	12,0	6	20	56,0	12	15,40	25
908192	HELU-S-PAB-AL/CU-DIN 25	25	35	31,0	6,8	12,0	6	20	61,5	12	16,00	25
908193	HELU-S-PAB-AL/CU-DIN 35	35	50	41,0	8,0	14,0	7	22	72,5	14	25,10	25
908194	HELU-S-PAB-AL/CU-DIN 50	50	70	41,0	9,8	16,0	8	25	78,0	16	34,50	25
908195	HELU-S-PAB-AL/CU-DIN 70	70	95	48,0	11,2	18,5	10	30	92,5	18	57,80	10
908196	HELU-S-PAB-AL/CU-DIN 95	95	120	48,0	13,2	22,0	12	33	95,0	22	86,40	10
908197	HELU-S-PAB-AL/CU-DIN 120	120	150	49,0	14,7	23,0	12	38	105,0	22	96,70	10
908198	HELU-S-PAB-AL/CU-DIN 150	150	185	58,5	16,3	25,0	12	38	117,5	25	115,20	5
908199	HELU-S-PAB-AL/CU-DIN 185	185	240	58,5	18,3	28,5	14	44	124,0	28	167,80	5
908200	HELU-S-PAB-AL/CU-DIN 240	240	300	69,0	21,0	32,0	16	44	136,5	32	223,00	5
908201	HELU-S-PAB-AL/CU-DIN 300	300	-	69,0	23,3	34,0	18	46	138,0	34	272,40	5
908202	HELU-S-PAB-AL/CU-DIN 400	400	-	70,0	26,0	38,5	20	52	150,0	38	379,00	5
908203	HELU-S-PAB-AL/CU-DIN 500	500	-	80,0	29,0	44,0	22	58	176,0	44	575,20	5

WK-SC-P Bolt Connector

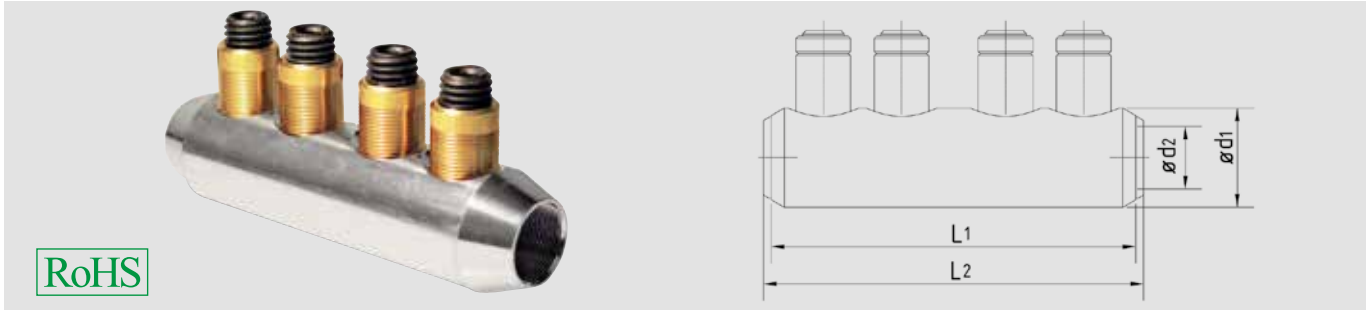

Technical Data

Material: Aluminium alloy
Surface: tin plated
Dimensions: $d_1 = 42 \text{ mm}$
 $d_2 = 26.2 \text{ mm}$
 $L_1 = 220 \text{ mm}$

Design

- with divider
- Conductor channel with transverse grooves and protection against conductor oxidation

These bolt connectors were developed especially for the HELUWIND® WK POWERLINE ALU and successfully tested according to IEC- DIN EN 61238-1 Class A.

SICON bolt connector

185-400 + 500 mm² RE Al/Cu + 300 flex

Thanks to the special design of the bolts, there are no predetermined breaking points in the threads. Instead the bolt always reliably rips on the surface of the terminal body.

- No protrusions on the terminal body
- Full utilization of the thread load carrying capacity for every conductor cross section
- No special tool required
- Gentle shearing off of the shear bolt makes tightening easier

fine-wire	185 - 240 (300 max. Ø 26 mm)	185 - 240 (300 max. Ø 26 mm)
SM 120°	185 (240 pressed round)	185 (240 pressed round)
SE 120°	185 - 240	
SM 90°	185 - 240	185 - 240
SE 90°	185 - 240	
RE	185 - 500	185 - 500
RMV	185 - 400	185 - 400
RM	185 - 400	185 - 400
Conductor types as per DIN 60228 - 09/2005	Cross section range: aluminium conductor	Cross section range: copper conductor

Other conductor cross sections and dimensions on request.

SICON –

The first stepless shear bolt

- 1 A standard hexagonal wrench works on a threaded pin which will be screwed into the hole of the stepless compression bolt. The traction is not interrupted by any step or notch on the bolt.
- 2 When screwing in the SICON bolt, the pressure plate loosens on the bottom of the bolt. The bolt now turns on this plate; compared to conventional bolts, no head friction occurs on the conductor. The bolt's torque generates the contact pressure almost independently of the conductor material. This way, a significantly higher contact pressure is achieved for Aluminium conductors and even fine-wired conductors are not damaged.
- 3 The SICON bolt continues to turn until the shearing moment is reached. When screwed in, the thrust bolt is tensioned; on reaching the shearing moment, it stretches axially and tears. Compared with conventional shear bolts, the bolt breaks very smoothly.
- 4 The SICON bolt always shears directly on the surface of the terminal body. This ensures that the protrusion is always minimized, irrespective of the conductor to be connected.

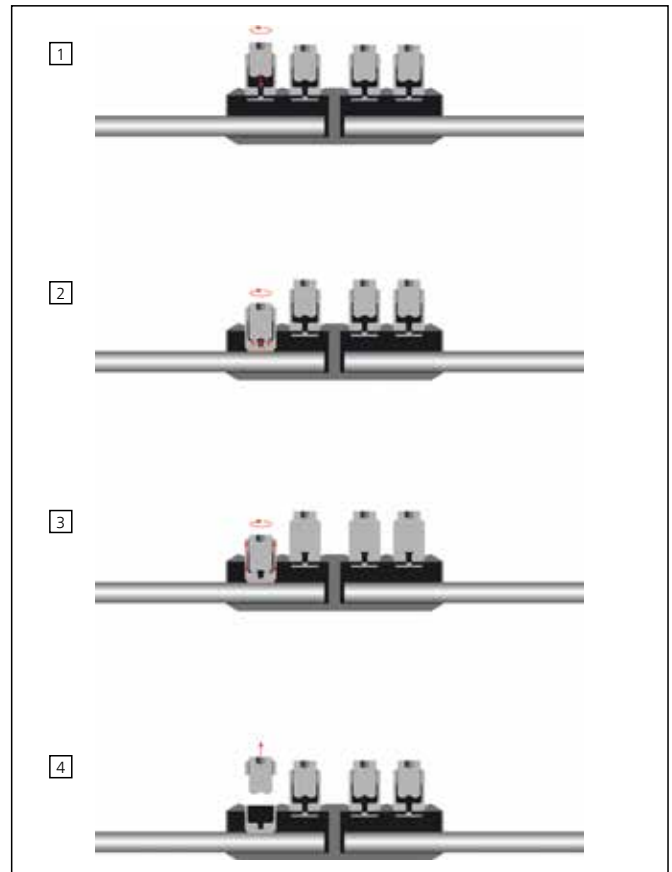

Dimensions and specifications may be changed without prior notice.

WK-SC-T Shear Bolt Connector



Bolt connector with shear bolts for HELUWIND® WK POWERLINE ALU fine-wire aluminium conductors.

A connection technology with dual shear bolts, especially developed for the WK POWERLINE ALU series. This newly-developed bolt technology differs from conventional techniques as the aluminium conductor is contacted in a 2-step-procedure. First of all, the dual bolt technology fastens the fine-wire aluminium conductor. As a second step a mandrel is inserted into the conductor, what completes the conductor's crucial sealing and contacting.

Properties

- Easy and secure connection system for flexible Cl. 5 aluminium cables tested according to IEC-61238-1 Class A.
- New patented two-step shear off bolts provide predetermined torque & ensure reliable and secure contact without damaging fine aluminium strands.
- Easier and faster installation - no tools required.
- Available for cable cross sections 70 mm² through 500 mm².
- Dual connection technology available for connecting the HELUWIND® WK POWERLINE ALU series.

Optional: Reduction Connector

HELUWIND® WK POWERLINE ALU series to Cl. 2 aluminium
HELUWIND® WK POWERLINE ALU series to Cl. 5 copper
Part no. and prices on request.

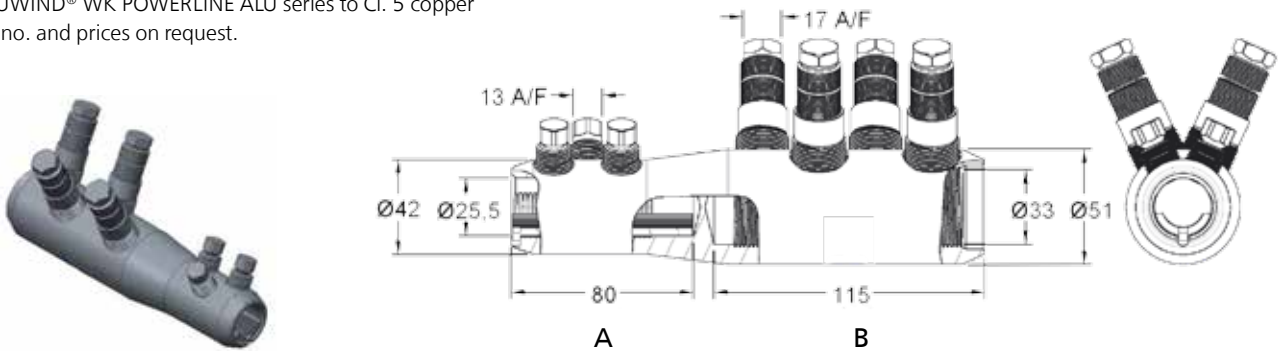

Diameter range table		AL					CU		
A	mm ²	150/400	150/400	150/240	185/300 (300 with 90°)		150 / 400	150/185	300 (Class 5)
	Ø mm	13,7 / 24,6	12,9 / 22,2				13,7 / 24,6		23,5 / 25
B	mm ²					400 (Class 5)			
	Ø mm					27 / 29			

Dimensions and specifications may be changed without prior notice.

WK-SL-T Shear Bolt Cable Lug



Bolt cable lug with shear bolts for HELUWIND® WK POWERLINE ALU fine-wire aluminium conductors.

A connection technology with dual shear bolts, especially developed for the HELUWIND® WK POWERLINE ALU series. This newly-developed bolt technology differs from conventional techniques as the aluminium conductor is contacted in a 2-step-procedure. First of all, the dual bolt technology fastens the fine-wire aluminium conductor. As a second step, a mandrel is inserted into the conductor, what completes the conductor's crucial sealing and contacting.

Properties

- Easy and secure connection system for Cl. 5, flexible aluminium conductors, tested according to IEC-61238-1 Cl. A.
- Patented two-step, shear off bolts provide predetermined torque & ensure reliable and secure contact without damaging fine aluminium strands.
- Easier and faster installation - no tools required.
- Available for cross sections: 70 mm² - 500 mm².
- Dual shear bolt cable lugs are designed for connecting the HELUWIND® WK POWERLINE ALU series.

Part no. and prices on request.

Bolt Cable Lug with Shear Head

For copper Cl. 5 and aluminium Cl. 2



RoHS

Bolt Cable Lug with Shear Head

Properties

- Available for cross sections 120 mm² through 400 mm²
- Tested according to IEC 61238-1 Cl. A
- Up to U_0/U_m 18/30 (36) kV
- Connector: High-strength aluminium alloy
- Threaded screws: aluminium alloy with multiple shear heads
- Surface: tin-plated for aluminium and copper conductors

Advantages

- Designed with insulation throughout the entire length
- Suitable for indoor and outdoor applications
- Particularly-long sealing length to protect against moisture

Not for fine-wire aluminium stranding.

Part no. and prices on request.

Bolt Connector with Shear Head

For copper Cl. 5 and aluminium Cl. 2



Bolt Connector with Shear Head

Properties

- Available for cross sections 10 mm² through 1000 mm²
- Tested according to IEC 61238-1 Cl. A
- Up to U_o / U (U_m) 18/30 (36) kV
- Connector: High-strength aluminium alloy
- Threaded screws: aluminium alloy with multiple shear heads
- Surface: tin-plated for aluminium and copper conductors

Advantages

- Greater connection area
- Conductor connection canal with longitudinal and lateral grooves, which allows for good electrical contacts and tearing up the oxide coating on the conductors

Not for fine-wire aluminium stranding.

Part no. and prices on request.

Dimensions and specifications may be changed without prior notice.

Mechanical Split Connector with Shear Head

For copper Cl. 5 and aluminium Cl. 2

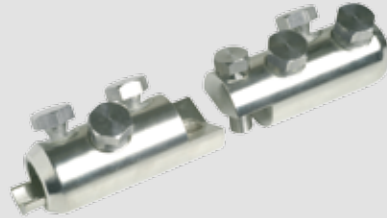

Mechanical Split Connector with Shear Head

Properties

- Available for cross sections 120 mm² through 400 mm²
- Tested according to IEC 61238-1 Cl. A
- Connector: High-strength aluminium alloy
- Threaded screws: aluminium alloy with multiple shear heads
- Surface: tin-plated for aluminium and copper conductors

Advantages

- Greater connection area
- Conductor connection canal with longitudinal and lateral grooves, which allows for good electrical contacts and tearing up the oxide coating on the conductors

Not for fine-wire aluminium stranding.

Part no. and prices on request.

Dimensions and specifications may be changed without prior notice.

Rollover Insulation Hose

For fixed connection of a 0.6/ 1kV single-conductor cable



Field of application

- Good versatility; for connecting and sealing single-conductor and coax cables
- Indoors, outdoors, soil, water, installation channels and pipes
- Ideal for locations without flames

Approval

- UL/CSA ANSI

Properties

- The hoses consist of a double-walled endless EPDM pipe filled with lubricant, which is easily rolled over the cable and connector.
- Large field of application, with only 4 types, the full low-voltage range is covered.
- UV-resistant and halogen-free
- Resistant against environmental and chemical influences such as alkalis in the soil.
- Suitable for press connectors (not included)

Advantages

- Reliable protection against moisture and water
- Quick and easy installation without tools
- Can be installed at up to -25°C without significant effort
- Voltage is immediately switched on after successful installation
- Continuous operation temperature range -40°C to +130°C
- Can be stored indefinitely

Part no. and prices on request.

Repair Sleeves for shielded single-conductor plastic cable

with bolt connector - U_0/U_m 6/10 (12) kV to 12/20 (24) kV



Sleeve

- Sleeve designed for 12 kV and 24kV plastic-insulated cables:
The main design of these sleeves matches the hereafter mentioned MXSU connection sleeves, in which the feeder terminal hose and the sleeve body are roughly twice as long. From prior experience a part of the cable or sleeve will need to be cut out when the cables are damaged, a longer repair bolt connector and a fibre-reinforced cuff are used to restore the conductor connection, which significantly reduces space requirements for the sleeve hole, since the outer hose's stop position is no longer necessary. This allows for bridging gaps up to 320 mm.

Pressure-resistant sleeve

- Pressure-resistant repair sleeves 24 kV:
This sleeve is a special product that was developed during the "Cable Cure" cable refurbishing process. The design matches the repair sleeve for plastic cables. The sleeve's required compressive strength is achieved by additional, pressure-resistant cuffs over the sleeve body. A bolt connector with the appropriate length allows for smooth replacement of the missing conductor piece after disassembling the existing connection sleeves. This application is available upon request.

Cable

- The sleeves described here are used for repairing cable errors and/or defective sleeves up to 320 mm long on plastic-insulated cables of up to 24 kV. This application is available for the following cables: N(A)YSY, N(A)2YSY, N(A)2XS(FL)2Y, N(A)2YHCaY, N(A)2XS(FL)Y. Additional cable types available upon request.

Note

- For cross sections from 25mm² to 500mm²

Part no. and prices on request.

Cable Fittings from Tyco Electronics Raychem GmbH

Cable connection RSTI

Screened, separable connection system RSTI, 630A up to 36kV, cross section: 25mm² - 630mm² for SF6-insulated switchgear with 630A bushings, Type C, 630/1250A according to CENELEC HD506 S1, EN 50180 and EN 50181



Coupling plug RSTI-CC

Screened, separable coupling connection system RSTI-CC, 630A up to 36kV, cross section: 25mm² - 630mm² in combination with connection system RSTI for SF6-insulated switchgear with 630A bushings, Type C, 630/1250A according to CENELEC HD506 S1, EN 50180 and EN 50181



Typical application in a switching system.

Medium-Voltage Cable Accessories

INLINE Junction Box up to 42 kV

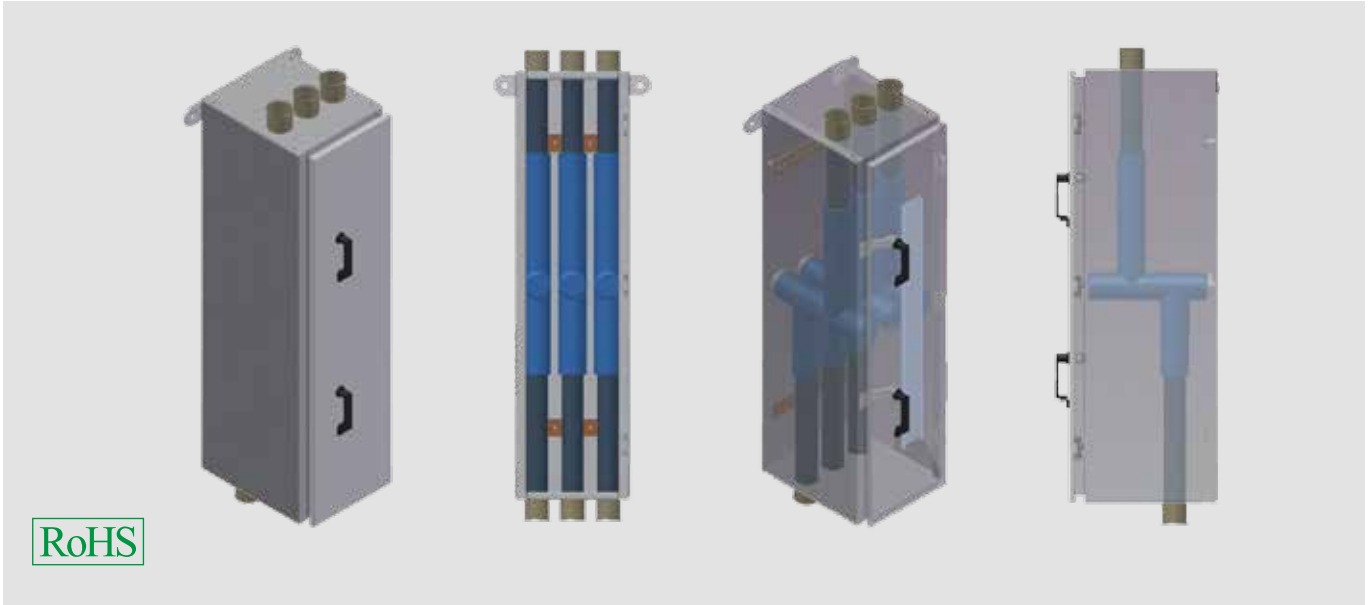

RoHS

Medium-voltage distributor connector for three insulated cable connectors, up to a max. of 42KV

The MS distributor connector saves a lot of space, thanks to the inline array of the insulated medium-voltage cable connectors, and is easy to install.

- Conductor cross section 25mm² to 300mm²
- Connection for many conductor materials, copper or aluminium cables
- Voltage level up to 42 kV
- Powder-coated metal housing
- On request: corrosion resistant high-grade steel for offshore uses
- Height: 1200mm/Depth: 400mm/Width: 320mm
- For medium-voltage cable connection set type RSTI

Part no. and prices on request.

IREV-S

Medium-voltage indoor termination for shrinking



IREV-S

The interior sealing ends are suitable for all single-conductor and three-conductor medium-voltage plastic cables with differing conductor layers and sheath designs up to 18/30(36)kV.

Properties

- Safe field effect
- Easy installation
- Broad application range
- Excellent external layer behaviour
- Unlimited storage stability
- Immediately operational

Scope of delivery

- Unit: 1
- Deferrable silicone control element
- Sealing band
- Creeping current resistant, weather-proof heat shrink tube
- Assembly instruction
- Deferrable silicone sheds

Note

- An additional grounding kit is required for cables with copper sheath.
- Without terminals.
- 1 unit = 1 set with 3 items.

Single core

Part no.	Type	Nominal voltage U_0/U_m	Cross-section mm^2	Unit	Price
93190	IREV-S12/1	6/10kV	10,0 - 25,0	1	on request
93191	IREV-S12/1	6/10kV	25,0 - 95,0	1	on request
94420	IREV-S12/1	6/10kV	95,0 - 240,0	1	on request
93192	IREV-S12/1	6/10kV	150,0 - 400,0	1	on request
93193	IREV-S12/1	6/10kV	240,0 - 500,0	1	on request
94421	IREV-S12/1	6/10kV	400,0 - 800,0	1	on request
94422	IREV-S12/1	6/10kV	800,0 - 1000,0	1	on request
94423	IREV-S24/1	12/20kV	10,0 - 35,0	1	on request
93194	IREV-S24/1	12/20kV	25,0 - 150,0	1	on request
93195	IREV-S24/1	12/20kV	70,0 - 240,0	1	on request
93196	IREV-S24/1	12/20kV	120,0 - 300,0	1	on request
93197	IREV-S24/1	12/20kV	240,0 - 500,0	1	on request
94424	IREV-S24/1	12/20kV	630,0 - 1000,0	1	on request
93198	IREV-S36/1	18/30kV	35,0 - 70,0	1	on request
94425	IREV-S36/1	18/30kV	50,0 - 150,0	1	on request
93199	IREV-S36/1	18/30kV	150,0 - 400,0	1	on request
93200	IREV-S36/1	18/30kV	500,0 - 800,0	1	on request

3-core

Part no.	Type	Nominal voltage U_0/U_m	Cross-section mm^2	Unit	Price
94435	IREV-S12/3	6/10kV	10,0 - 25,0	1	on request
93201	IREV-S12/3	6/10kV	25,0 - 95,0	1	on request
93202	IREV-S12/3	6/10kV	95,0 - 240,0	1	on request
93203	IREV-S12/3	6/10kV	150,0 - 400,0	1	on request
94436	IREV-S24/3	12/20kV	10,0 - 35,0	1	on request
94437	IREV-S24/3	12/20kV	25,0 - 95,0	1	on request
94438	IREV-S24/3	12/20kV	70,0 - 240,0	1	on request
94439	IREV-S24/3	12/20kV	120,0 - 300,0	1	on request

Dimensions and specifications may be changed without prior notice.

FLEV-S

Outdoor termination, shrinking type



FLEV-S

The outside sealing ends are suitable for all single-conductor and three-conductor medium-voltage plastic cables with differing conductor layers and sheath designs up to 18/30(36)kV.

Properties

- Safe field effect
- Easy installation
- Broad application range
- Excellent external layer behaviour
- Unlimited storage stability
- Immediately operational

Scope of delivery

- Unit: 1
- Deferrable silicone control element
- Sealing band
- Creeping current resistant, weather-proof heat shrink tube
- Assembly instruction
- Deferrable silicone sheds

Note

- An additional grounding kit is required for cables with copper sheath.
- Without terminals.
- 1 unit = 1 set with 3 items.

Single core

Part no.	Type	Nominal voltage U_0/U_n	Cross-section mm^2	Unit	Price
93360	FLEV-S12/1	6/10kV	10,0 - 25,0	1	on request
93361	FLEV-S12/1	6/10kV	25,0 - 95,0	1	on request
94426	FLEV-S12/1	6/10kV	95,0 - 240,0	1	on request
93362	FLEV-S12/1	6/10kV	150,0 - 400,0	1	on request
93363	FLEV-S12/1	6/10kV	240,0 - 500,0	1	on request
94427	FLEV-S12/1	6/10kV	400,0 - 800,0	1	on request
94428	FLEV-S12/1	6/10kV	800,0 - 1000,0	1	on request
94429	FLEV-S24/1	12/20kV	10,0 - 35,0	1	on request
93364	FLEV-S24/1	12/20kV	25,0 - 150,0	1	on request
93365	FLEV-S24/1	12/20kV	70,0 - 240,0	1	on request
93366	FLEV-S24/1	12/20kV	120,0 - 300,0	1	on request
93380	FLEV-S24/1	12/20kV	240,0 - 500,0	1	on request
94430	FLEV-S24/1	12/20kV	630,0 - 1000,0	1	on request
93367	FLEV-S36/1	18/30kV	35,0 - 70,0	1	on request
93368	FLEV-S36/1	18/30kV	50,0 - 150,0	1	on request
93369	FLEV-S36/1	18/30kV	150,0 - 400,0	1	on request
93370	FLEV-S36/1	18/30kV	500,0 - 800,0	1	on request

3-core

Part no.	Type	Nominal voltage U_0/U_n	Cross-section mm^2	Unit	Price
94443	FLEV-S12/3	6/10kV	10,0 - 25,0	1	on request
93371	FLEV-S12/3	6/10kV	25,0 - 95,0	1	on request
93372	FLEV-S12/3	6/10kV	95,0 - 240,0	1	on request
93373	FLEV-S12/3	6/10kV	150,0 - 400,0	1	on request
94444	FLEV-S24/3	12/20kV	10,0 - 35,0	1	on request
94445	FLEV-S24/3	12/20kV	25,0 - 95,0	1	on request
94446	FLEV-S24/3	12/20kV	70,0 - 240,0	1	on request
94447	FLEV-S24/3	12/20kV	120,0 - 300,0	1	on request

Dimensions and specifications may be changed without prior notice.

Cable Fittings from Tyco Electronics Raychem GmbH

Medium-voltage

MXSU Heat-shrink joint

Heat-shrink joint MXSU for polymeric insulated cables up to 36kV, cross section: 25mm² - 500mm² incl. mechanical connectors



SXSU Heat-shrink joint

Heat-shrink joint SXSU for polymeric insulated cables up to 36kV, cross section: 25mm² - 1200mm² for compression joints



Low-voltage

UAGA Heat-shrink joint

Heat-shrink joint UAGA for polymeric insulated cables up to 1kV, cross section: 1.5mm² - 300mm²



VMDU Heat-shrink joint

Heat-shrink joint VMDU for control cables, cross section: 4 - 75 x 1.5mm² - 2,5mm²



SK-D

Heat-shrink tube 3:1 with inside adhesive, polyolefine, thick-walled



SK-D

Polyolefine shrink tube with inside adhesive for repairing insulation and sealing electrical components.

For the protection of cable sleeves and terminations for low-voltage applications (600V).

Good protection against impact and abrasion.

Material

- PO (Polyolefine) with inside adhesive
- Colour: black
- halogen-free

Technical Data

Temperature range: -55°C up to +110°C.

Note

Form of shipment: 1.2 m rods
Approval: UR-listed up to size 68,1 mm

Application

- Plant and machine construction
- Robot construction
- Automation technology
- Vehicle construction and shipbuilding
- Installation technology
- Control cabinet construction

Black

Part no.	Inner Ø before shrinkage mm	Wall thickness mm	Inner Ø after shrinkage mm	Content m	Unit	Price
905344	8,9	1,8	3,0	rods of 1,22m	1	on request
905335	13,0	2,4	4,1	rods of 1,22m	1	on request
905336	19,1	2,4	6,1	rods of 1,22m	1	on request
905337	27,9	3,0	8,9	rods of 1,22m	1	on request
905338	38,1	4,1	11,9	rods of 1,22m	1	on request
905339	50,8	4,1	16,0	rods of 1,22m	1	on request
905340	68,1	4,1	22,1	rods of 1,22m	1	on request
905731	89,9	4,1	30,0	rods of 1,22m	1	on request
905732	119,9	2,0	39,9	rods of 1,22m	1	on request

Dimensions and specifications may be changed without prior notice.

■ Connection technology for HELWIND® WK POWERLINE ALU Series

		Cross-section mm ²									
		drilling	50	70	95	120	150	185	240	300	400
HELU-S-PK-AL-DIN 		10	907873	907875	907877	907880	906459	-	-	-	-
		12	907874	907876	907878	907881	906436	906463	906469	906472	906475
		16	-	-	907879	907882	906461	906464	906470	906473	906476
		20	-	-	-	-	906462	906465	906471	906474	906477
HELU-S-PK-AL-FG 		10	-	-	906539	906541	906544	906547	-	-	-
		12	-	-	906540	906542	906545	906548	906553	906556	906559
		16	-	-	-	906543	906546	906549	906554	906557	906560
		20	-	-	-	-	-	-	906555	906558	906561
HELU-S-PK-AL/CU 		10	907578	907581	907585	907589	906478	906479	906486	906490	906491
		12	907579	907582	907586	907590	906172	906480	906487	906212	906492
		16	-	907583	907587	907591	906173	906481	906488	906174	906493
		20	-	-	-	-	-	906482	906489	906175	906494
HELU-S-PV-AL-DIN 			-	-	906515	906516	906406	906517	906519	906520	906521
HELU-S-PAB-AL-DIN 			908301	908302	908303	908304	908305	908306	908308	908309	908310
HELU-S-PAB-AL/CU-DIN 			908194	908195	908196	908197	908198	908199	908201	908202	908203
WK-SC-P bolt connector 			-	-	-	-	-	o.r.		-	
WK-SC-T shear bolt connector 			-	-	-	o.r.		o.r.		o.r.	
WK-SL-T shear bolt cable lug 			-	-	-	o.r.		o.r.		o.r.	
HELU-S-PV-AL/CU 		ALU/CU	150/70	150/95	150/120	150/150	185/95	185/120	185/150	185/185	
			906460	906495	906209	906496	906497	906498	906499	906500	
		ALU/CU	240/150	240/185	240/240	300/185	300/240	300/300	400/240	400/300	400/400
		906505	906506	906507	906509	906210	906510	907860	907861	907862	

Dimensions and specifications may be changed without prior notice.
o.r. = on request

Tools for -Crimp, see WK-API 18, page 73.

TOOLS





WK-API 18 Electro-hydraulic, hand-held, battery-operated press tool

- Special tool for crimping larger cross sections
- Very solid crimping head particularly suitable for special crimping dies with larger crimping widths; allowing for fast processing of larger cross sections
- Pressing force: 130 kN
- Max. stroke: 42 mm
- Head opening: 42 mm
- Operating pressure: 700 bar (70 MPa)
- Dimensions: W 95mm x L 430mm x H 310mm
- Weight: approx. 7,5 kg
- Rechargeable battery: Li-Ion; 14,4V; 3,0Ah
- Battery charger: 220-240V; 50-60Hz; 7,2-18V
- Battery charging time: approx. 50 minutes
- HELUWIND WK POWERLINE ALU (finely stranded) up to 400mm²
- Aluminium Cl.2 up to 500mm²

Part no.	Type	Unit	Net EUR/item at a purchase of		
			1	2 - 4	5 - 10
906647	WK-API 18	1	o. r.	o. r.	o. r.

Dimensions and specifications may be changed without prior notice.

o. r. = on request

C8-Crimping dies for HELUWIND® WK POWERLINE ALU

Part No.	Cross Section
907014	95 mm ² + adapter 906411
906434	150 mm ²
907200	185 mm ²
906446	240 mm ²
906206	300 mm ²
906766	400 mm ²

Please order crimping dies separately!

WK-electro-hydraulic, battery-operated pump



WK-electro-hydraulic, battery-operated pump

- Light, compact and robust structure
- Double piston technology for rapid, high-pressure feed
- Quick tool return by high return conveyor volume
- Pressure monitoring with an electronic pressure sensor
- High-performance battery (lithium-ion) with charge level indicator
- Remote control, 1.5 m
- Power button located on the device and on the remote control
- Remote controlled hydraulic cylinder
- Control by means of microcontroller
- LED-display (green) for correct processing on the device and remote control
- LED-display for battery and processing errors on the device
- Automatic energy save mode after 5 min. in idle
- Crimp and error message history on internal memory (app. 100000 cycles)
- Read out of all cycles and error messages from USB
- Permanent supervision of remaining battery load prevents uncompleted crimping cycles
- Controlled engine drive for long life of gear, engine and battery

- Automatic and manual retract, retract stop function
- Increased cutting frequency by means of automatic cutting detection (pat. pending)
- Integrated service-management
- Software update from USB connection
- Temperature monitor
- Pump can be carried using shoulder strap, carry bag with additional pockets
- Remote control can be fastened to the pump, belt or shoulder strap
- C8-crimp
- Capacity within the range of low pressure <100 bar: 1.15 lit./min.
- Capacity within the range of high pressure up to 700 bar: 0.15 lit./min.
- Operation pressure: 700 bar (70 MPa)
- Power: 200 W
- Battery voltage: 18 V DC
- Battery capacity: 3.0 Ah
- Operating temperature: -20° C / +55° C
- Measurements (W x L x H): 290 x 190 x 205 mm
- Weight: approx. 4.6 kg (with battery)

Scope of delivery

- Battery-operated pump
- Remote control, 1,5m
- Flexible hose, 1,5m
- USB cable
- Li-Ion battery, 18V, 3,0Ah
- Battery charger
- Software (CD)
- Shoulder strap
- Carry bag with additional pockets

Note

Pressing cylinder and crimping head are not part of the product. Please order separately.

Part no.	Type	Unit	Net EUR/item at a purchase of		
			1	2 - 4	5 - 10
906207	WK-Electro hydraulic pump with battery	1	o. r.	o. r.	o. r.

Dimensions and specifications may be changed without prior notice.

o. r. = on request

WK-electro-hydraulic radial-piston-pump (230 V) with transport cart



WK-Electro-hydraulic radial-piston-pump (230V) with transport cart

- Electrical controls
- Pressure control valve
- Magnet valve
- Oil sight glass
- 3 meter high-pressure hose
- Pump controlled with a foot pedal which is equipped with a high-quality, 3-point safety switch
- Operating pressure: max. 700 bar
- Operating voltage: 230V, 50Hz
- Delivery rate: 0,64l/min
- Nominal capacity: 0,75 kW
- Foot pedal with one switch
- Weight: 32,5 kg

Note

Without cutting and crimping tool
Optional: 400V version available

Scope of delivery

- Battery-operated hydraulic compression tool
- Battery
- Charger
- Transport cart

Part no.	Type	Unit	Net EUR/item at a purchase of		
			1	2 - 4	5 - 10
906721	-	1	o. r.	o. r.	o. r.

Dimensions and specifications may be changed without prior notice.

o. r. = on request

HELUTOOL HMPI 20 Mechanical hand press in toolbox



HELUTOOL HMPI20 Hand-operated mechanical compression tool

Hand-operated mechanical compression tool for crimping cable lugs and connectors up to 300mm²

- Light and compactly construction form
- Universal usage: dies for all versions of cable lugs are available
- 360° revolving head with quick opening and closing
- Continuous moveable telescopic handle
- Press capacity: approx. 60 kN
- Length: 560 up to 830 mm
- Weight: 3,6 kg

Note

Exclusive inserts

Suitable crimping dies

HELU-S-PE-SK
HELU-S-PE-WM

Other crimping dies on request

Scope of delivery

HELUTOOL HMPI200 including toolbox

Part no.	Type	Cross-section min. - max. mm ²	Unit	Net EUR/item at a purchase of		
				1	2 - 4	5 - 10
907614	HMPI 20	-	1	o. r.	o. r.	o. r.

Dimensions and specifications may be changed without prior notice.

o. r. = on request

HELUTOOL HHPI 20 Hydraulic hand press in toolbox



HELUTOOL HHPI 20 Hydraulic hand press in toolbox

- extremely fast operation through two-stage hydraulic pump
- large processing area up to 300mm²
- rotatable quick release head 180 °
- with folding clasp for effortless operation even in hard reach places
- lightweight and portable, compact design
- built-in pressure relief valve, even in the case of a false pressing no damage to the tool and inserts
- universally applicable: inserts are available for all cable lug types
- Press capacity: ca. 62kN
- Length: 396 mm
- Weight: ca. 2,8 kg

Note

Exclusive inserts

Suitable crimping dies

HELU-S-PE-SK

HELU-S-PE-WM

Other crimping dies on request

Scope of delivery

HELUTOOL HHPI 20 including toolbox

Part no.	Type	Unit	Net EUR/item at a purchase of		
			1	2 - 4	5 - 10
908286	HHPI 20	1	o. r.	o. r.	o. r.

Dimensions and specifications may be changed without prior notice.

o. r. = on request

HELUTOOL HAPI 20 Battery hydraulic tool in toolbox



HELUTOOL HAPI 20 Battery hydraulic tool in toolbox

- extremely fast working through two-stage hydraulic pump
- large processing area up to 300 mm²
- Quick release fastener 270 ° rotatable
- Effortless operation by folding clasp even in hard reach places
- Pressure relief button by hand operation available from both sides (left and right)
- Built-in relief valve, even at erroneous pressing no damaging the tool or inserts
- Lithium-ion battery technology, thereby no memory effect, very low self-discharge
- high capacity by 3.0 Ah-battery
- Lug for attaching balancers and carrying belt available
- ergonomic handle with a balanced weight distribution for fatigue-free and safe work
- Casing grip sleeve and pressure relief button entirely of insulating and shock-resistant plastic material
- universal application: inserts for all types of cable shoes available
- built-in electronic module for:
 - Permanent battery power level control
 - Monitoring of the operation and status indication
 - Display of the next service interval
 - Error indication in case of malfunction
- Press capacity: about 62kN
- Operating voltage: 14,4 Volt
- Dimensions (WxHxD):
B 95 x L 350 x H 310 mm
- Weight: 3,9 kg (incl. Battery)
- Charger: 220-240V 50-60Hz 7.2 - 18V
- Charging time approx 50 min.

Note
exclusive dies
For cross sections: 10-240 mm²

Scope of delivery
HELUTOOL HAPI including toolbox

Part no.	Type	Unit	Net EUR/item at a purchase of		
			1	2 - 4	5 - 10
908287	HAPI 20	1	o. r.	o. r.	o. r.

Dimensions and specifications may be changed without prior notice.

o. r. = on request

HELU-S-PE-SK Inserts hexagonal-shape



Inserts for cable lugs and connectors

For processing HELU-S-PK compression cable lugs and HELU-S-PV tubular compression joints

Note

Suitable for:
HELUTOOL HMPI 20, HHPI 20 and HAPI 20

Part no.	Type	Code type	Cu mm ²	Al mm ²	Unit	Net EUR/item at a purchase of		
						1	2 - 4	5 - 10
908273	SKCU6	5	6	-	1	o. r.	o. r.	o. r.
908274	SKCU10	6	10	-	1	o. r.	o. r.	o. r.
908275	SKCU16	8	16	-	1	o. r.	o. r.	o. r.
908276	SKCU25AL10	10	25	10	1	o. r.	o. r.	o. r.
908277	SKCU35AL16/25	12	35	16 + 25	1	o. r.	o. r.	o. r.
908278	SKCU50AL35	14	50	35	1	o. r.	o. r.	o. r.
908279	SKCU70AL50	16	70	50	1	o. r.	o. r.	o. r.
908280	SKCU95AL70	18	95	70	1	o. r.	o. r.	o. r.
908281	SKCU120	20	120	-	1	o. r.	o. r.	o. r.
908282	SKCU150AL95/120	22	150	95 + 120	1	o. r.	o. r.	o. r.
908283	SKCU185AL150	25	185	150	1	o. r.	o. r.	o. r.
908284	SKCU240AL185	28	240	185	1	o. r.	o. r.	o. r.
908285	SKCU300AL240	32	300	240	1	o. r.	o. r.	o. r.

Dimensions and specifications may be changed without prior notice.

o. r. = on request

KST 1 cable shear



Cable shear KST 1

- with telescopic handles
- for Cu- and Al-cables, single and multi-core
- Cutting range: up to 26mm
- Length: 350 - 520 mm
- Weight: 1400 g

Part no.	Type	Unit	Net EUR/item at a purchase of		
			1	2 - 4	5 - 10
99087	KST 1	1	o. r.	o. r.	o. r.

Dimensions and specifications may be changed without prior notice.

o. r. = on request

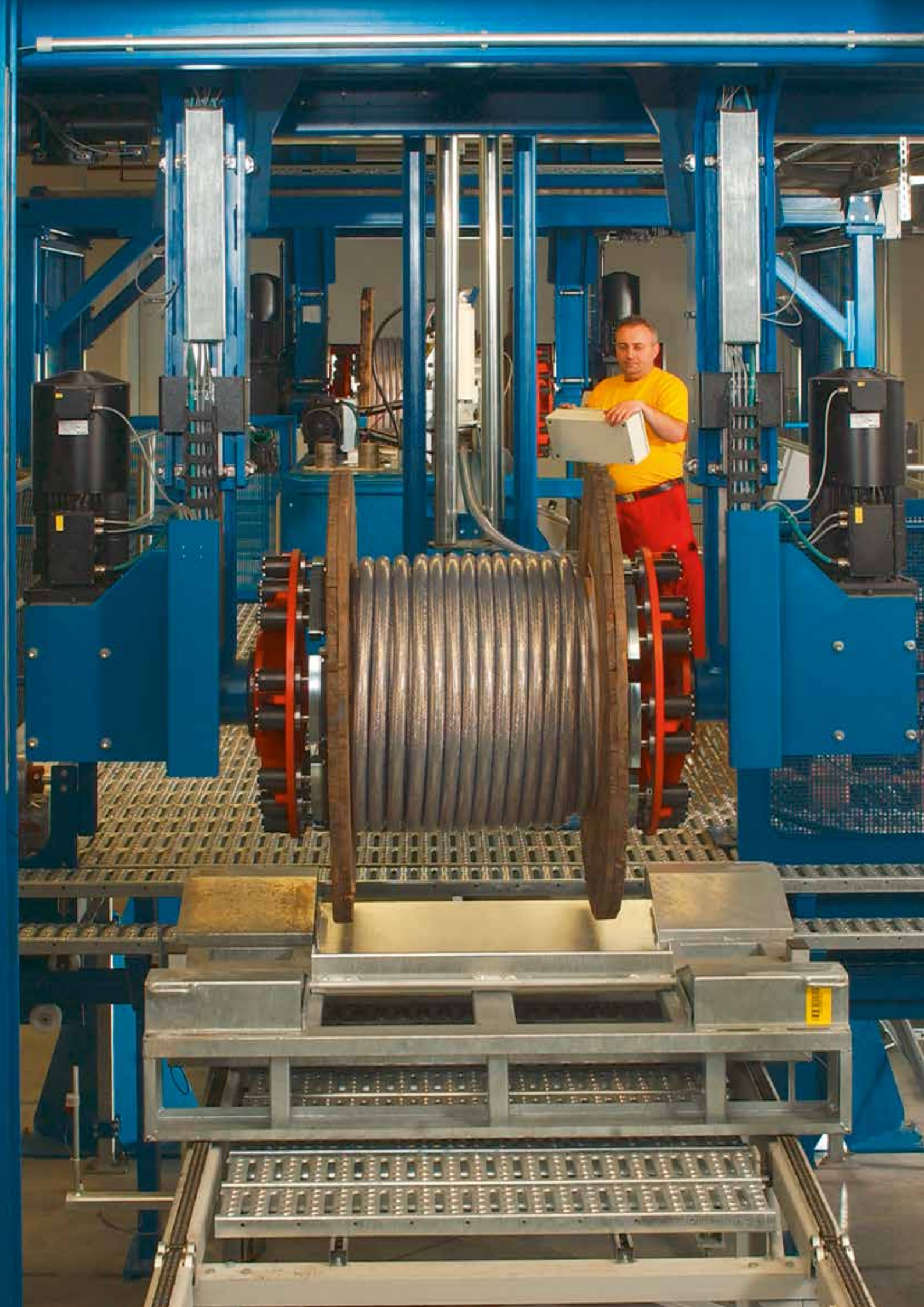

CURRENT-CARRYING CAPACITY TABLES



■ CURRENT-CARRYING CAPACITY TABLES

Due to legal restrictions, the chapter „Current carrying capacity tables“ is only available in the printed version.

To order your free copy, please visit www.helukabel.de/publication-order or fill out and send the form below.

■ FAX ANSWER TO: +49 7150 9209-5501

Yes, please sent us pc. of the catalogue „Aluminum Cable and wires“.

pc. Catalogue „Cable & Wires“

pc. Catalogue „Wind Power“

pc. Catalogue „Cable Accessories“

pc. Brochure „Photovoltaic“

pc. Catalogue „Media Technology“

Your contact details

Company

First name, Last name

Street

ZIP

City

Phone

E-mail

Yes, please include me in the mailing list for the HELUKABEL® e-mail newsletter.

Order catalogue online?

Please visit our website
www.helukabel.de/publication-order



PROCESSING INSTRUCTIONS



HELUKABEL <VDE> 0276 NAYY-J 0,6/1KV

WK Powerline ALU Multi 0,6/1KV

HELUWIND WK Powerline ALU single

HELUKABEL NA2XS(F)2Y 18/30KV

5 ALU shielded 25KV

■ PROCESSING INSTRUCTIONS FOR ALUMINIUM CABLE WITH ALUMINIUM AND ALUMINIUM/COPPER COMPRESSION CABLE LUGS AND PRESS CONNECTORS

Aluminium's material characteristics differ greatly from those of copper. Therefore, only use cable lugs and connectors made of aluminium or an aluminium/copper combination.

Cable lugs

Aluminium compression cable lugs

Material: Al 99.5, with pipe measurements pursuant to DIN 46329, insulated throughout the entire length pursuant to DIN 46239.

Optional: tin-plated thin layer, tin-plated thick layer.

Nominal cross section: 10 mm² - 500 mm² (custom-made products: up to 1000 mm²)

Aluminium/copper compression cable lugs

Material: Al 99.5 and Cu pursuant to DIN EN 13601; Surface: bare.

Nominal cross section: 10 mm² - 500 mm² (custom-made products: up to 1000 mm²).

To obtain the optimum fill factor, it is important that the conductor's diameter and the inner cable lug diameter are ideally matched to one another. Small gaps and ideal friction are important for destroying the non-conductive oxide coating.

The markings on DIN cable lugs contain information on:

- Manufacturer ID
- Tool reference number
- Metric screw measurement of the bore hole for the connection bolts
- Nominal cross section of the wire in mm²
- RE/SE = Single-wire round conductor/sector-shaped conductor
- RM/SM = Multi-wire round conductor/sector-shaped conductor

Example:

12-150RM/SM-185SE stands for:

12: Metric screw measurement of the bore hole for the connection bolts

150: Nominal cross section of the wire in mm²

RM/SM: Multi-wire round conductor and sector-shaped conductor

185: Nominal cross section of the wire in mm²

SE: Single-wire sector-shaped conductor

K25: Tool reference number

Press connector

Aluminium press connector

Material: Al 99.5 with pipe measurements pursuant to DIN 46267, Part 2; Surface: bare.

Nominal cross section: 10 mm² - 500 mm² (custom-made products: up to 1000 mm²).

Aluminium/copper press connectors

Material: Al 99.5 and Cu pursuant to DIN EN 13601; Surface: bare.

Nominal cross section: 10 mm² - 500 mm² (custom-made products: up to 1000 mm²).

A.

Aluminium conductor crimping die categories:

RE = Single-wire round conductor

SE = Single-wire sector-shaped conductor

RM = Multi-wire round conductor

SM = Multi-wire sector-shaped conductor

In general, it is recommended to use standardised 6-corner crimping dies pursuant to DIN 48083, part 4.

To ensure proper grouting, make sure that the press tool insert that is used always matches the tool reference number on the cable lug or connector. The reference number is mirror inverted on the press surface of the insert to ensure that the reference number remains visible for monitoring and documentation purposes after grouting.

B.

Aluminium conductor crimping die categories:

Fine-wire strand

(POWERLINE ALU Series)

The standard crimping technique is not recommended for a fine-wire aluminium conductor design. For the POWERLINE ALU series, we recommend our specially-developed C8 crimp that is tested according to IEC 61238-1 Cl. A. C8 crimp contours penetrate very deeply into the stranded bundle, equally tear up the individual strands, and make them conductive. With this process, the best values (low contact resistances) and mechanical extraction forces can be reached. The C8 crimp was also tested on multi-wire round conductors (RM).

■ PROCESSING INSTRUCTIONS FOR ALUMINIUM CABLE WITH ALUMINIUM AND ALUMINIUM/COPPER COMPRESSION CABLE LUGS AND PRESS CONNECTORS

Processing steps

for a secure and reliable connection

- 1) Dismantle the aluminium conductor
- 2) Remove the oxide coating from the conductor ends to create a clean contact surface.
We recommend using a brass brush solely used for this purpose.
- 3) Immediately grease the conductor ends after removing the oxide coating to prevent re-oxidation.
- 4) Repeat steps 2) and 3) if the conductor can not be connected immediately.
- 5) Slide the entire cable lug/press connector insertion sleeve over the conductor. While doing so, the contact grease will ooze out from the sides, thereby creating an air-tight seal that prevents re-oxidation.
- 6) Perform C8 or 6-corner crimping, depending on the conductor.
- 7) The connector's side contact surface (current rail) should be treated as described in No. 2.
Optional: Treat the contact surface with contact grease.
- 8) Tighten clamping point after approx. 200 operating hours.

Pressing procedure

Crimp the cable lug and/or connector using the assigned tools while taking into account the pressing direction. All DIN compression cable lugs have markings for proper crimping. Refer to the manufacturer's specifications for information on the number of markings (crimps). The correct pressing direction runs in the direction of the conductor, since the conductor material tends to slide out during crimping.

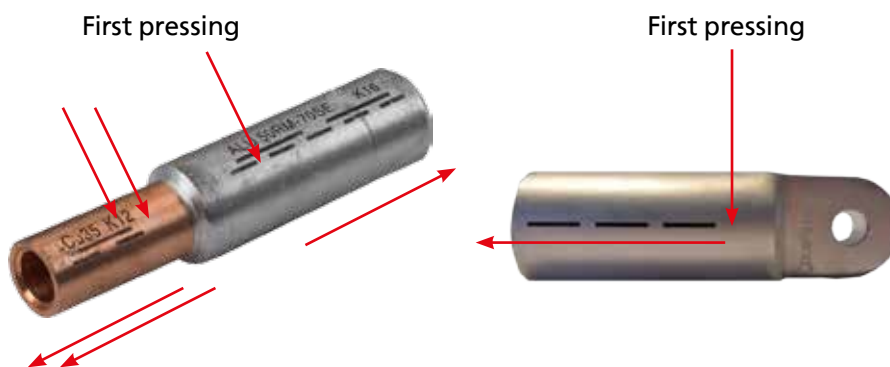

Insulation after crimping

To prevent corrosion and damage to aluminium conductors in compression cable lugs and/or press connectors, we generally recommend using insulated shrink tubes (warm/cold/rolling-shrink tubes). The shrink tubes used must match the application's dielectric strength. Furthermore, the shrink tube's wall thickness must be selected depending on the mechanical load during installation and operation. When vertically laying the cable or in areas with excessive condensation build-up, we recommend using a shrink tube with inside adhesive that prevents moisture from entering the crimped connection over the long run.

Examples:

- SK-D (thick-walled) under heavy load
- SK-M (medium-wall thickness)
- SK (thin-walled) under low mechanical load



HELUKABEL®



Logistics-Centre Hemmingen / Stuttgart